



LLAMBRICH
Super Precision Drill Chucks

CATALOGUE 2012-13

LLAMBRICH

LLAMBRICH

Super precision drill chucks

From our headquarters in the province of Barcelona, Spain, Llambrich Precision, S.L. has been designing and manufacturing drill chucks and machine tool accessories since 1957. The recognized quality and bottom line of our products has allowed us to export our products for more than 50 years to countries worldwide.

We are fully committed to the research and development for the continuous improvement for all of our products. Because of this we can offer an exclusive full range of drill chucks to meet our customer's needs and demands.

Llambrich's name stands for quality and innovative design worldwide, and are proud to hold both ISO 9001 & 13485 certifications.



() New HYBRID drill chuck for the medical industry, patented by Llambrich.*

Precision is our standard

MANUFACTURING PROGRAM

Our wide range of products includes drill chuck and machine tool accessories for portable tools, machine tools and medical applications.

Llambrich drill chucks are designed for high precision drilling. All of our products are made on and inspected by state of the art equipment.

QUALITY STATEMENT

Llambrich is proud to hold both ISO 9001 and ISO 13485 certifications.

PRODUCT INNOVATION

MEDICAL "INOX" LINE

Llambrich's stainless chucks program for surgical instruments

Llambrich offers the most complete Stainless Steel Drill Chuck range for use in manual, electric & pneumatic Surgical Instruments.

Llambrich is the only drill chuck manufacturer in the world to hold the ISO 13485 certification for medical drill chuck products.

Llambrich's INOX drill chucks are designed and manufactured for the most demanding medical applications.

THE "HYBRID"

THE HYBRID is a unique drill chuck developed and patented by Llambrich combining the precision of a keyless chuck with the gripping force of a keyed chuck.

THE HYBRID is available in steel for machining applications and Stainless steel for medical applications.

THE HYBRID is another example of a solution first offered by Llambrich, the worldwide leader in drill chucks based in Barcelona, Spain.

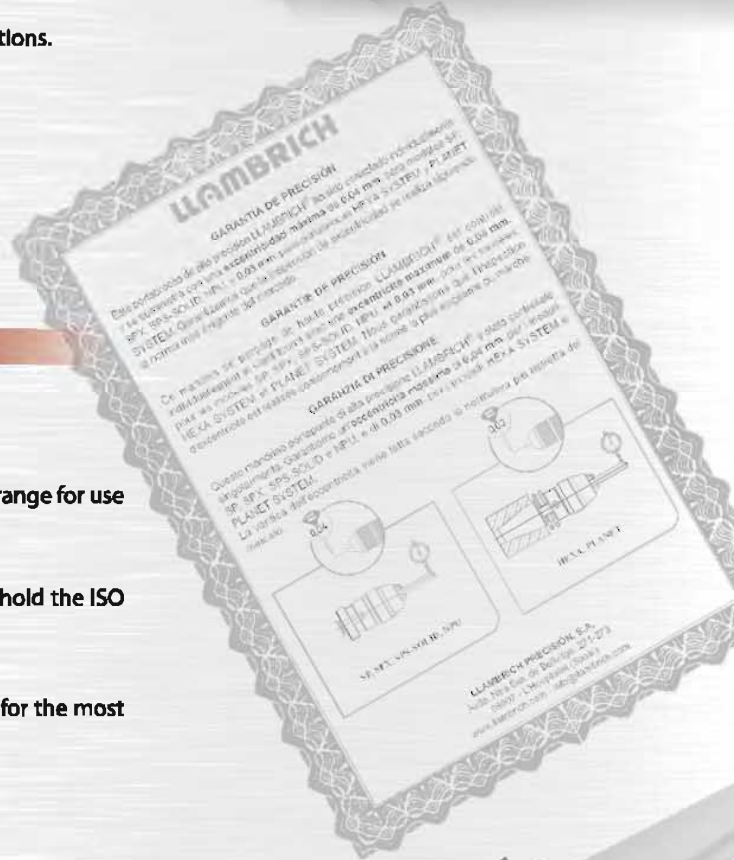

ISO 9001
ISO 13485



Index

Page 6 & 7

HYBRID

Combined precision keyless and keyed drill chuck

▶ SPH

NEW



Page 8 & 9

SP, SPX, SPS-SOLID

Precision self-tightening Drill Chucks

- ▶ SP
- ▶ SPX
- ▶ SPS-SOLID



Page 10 & 11

NPU

Precision self-tightening Drill Chucks with Integrated Shank

- ▶ DIN-69871, MAS-BT, DIN-2080,
- ▶ CAT-ANSI, VDI, STRAIGHT SHANK,
- ▶ HSK, NPU-B (drill chuck head)



Page 12, 13, 14 & 15

HEXA

Precision Drill Chucks with integrated Shank and Hexagonal Key lock

- ▶ DIN-69871, MAS-BT, DIN-2080, HSK,
- ▶ MORSE, STRAIGHT SHANK, VDI, CAT-ANSI
- ▶ R-8, HEXA-B (drill chuck head)

HEXA BLACK

Standard Drill Chucks with integrated Shank and Hexagonal Key lock

- ▶ DIN-69871, MAS-BT,
- ▶ DIN-2080, CAT-ANSI

NEW



Page 16 & 17

MICRO DRILL

Micro Drill Chucks and Adapters

- ▶ Micro Drill Chucks
- ▶ Sensitive Drill Adapters
- ▶ KITS

NEW



Page 18 & 19

CKS, CKX, CPL, CPX & CPM

Self-tightening Drill Chucks - medium duty -
Keyless Drill Chuck for portable drilling machines

- ▶ CKS Self-tightening
- ▶ CKX Self-tightening + with security lock
- ▶ CPL
- ▶ CPX
- ▶ CPM



Page 20 & 21

CY, CBB, CL & SDS-Converter

Key-type Drill Chucks
SDS Drill Chuck

- ▶ CY
- ▶ CBB
- ▶ CL
- ▶ SDS-Converter



Page 22 & 23

INOX

Stainless Steel Drill Chucks for medical and dental applications

- ▶ SP-INOX
- ▶ SPH
- ▶ CSS

NEW

*Includes the HYBRID chuck
in Stainless Steel version*



Page 24 & 25

Revolving LATHE CENTRES

- ▶ Precision Revolving Lathe Centres
- ▶ Revolving Lathe Centres with small casing diameter



Page 26 & 27

Arbors, Drill Sleeves and Ejectors

- ▶ Arbors
- ▶ Drill Sleeves
- ▶ Extension Sleeves
- ▶ Ejectors



innovation, quality



HYBRID

This unique chuck, designed and patented by Llambrich combines the features and benefits of both a keyed and keyless drill chuck.



- Another solution offered first by the world's leader of drill chucks from Barcelona, Spain, Llambrich.
- The Hybrid combines the high accuracy of a keyless chuck with the gripping force of a keyed chuck.
- Self-tightening feature automatically increases gripping force in proportion to the increase of torque to prevent tool slippage.

Features & Benefits

The Hybrid is furnished with a key to allow additional gripping torque.

The tool better resists loosening on high speed machines that have instant spindle stop. .04 mm (.0016") repeatability on taper mounted chucks. Llambrich, the leader in precision.

Special designs, sizes, and mounts for all types of applications are available upon request.

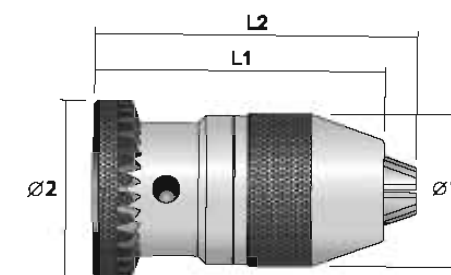

Model No.	Capacity		Mount K	Key Model	Sizes mm.				Weight gr
	mm.	inches			Ø1	Ø2	L1	L2	
SPH-06 B12	0,3-8	1/64"-5/16"	B12	K2/S17	36,5	44	72	77	460
SPH-06 J1	0,3-8	1/64"-5/16"	J1	K2/S17	36,5	44	72	77	460
SPH-10 B12	0,8-10	1/32"-3/8"	B12	K2/S17	40	48	79	85,5	620
SPH-10 B16	0,8-10	1/32"-3/8"	B16	K2/S17	40	48	79	85,5	620
SPH-10 J2	0,8-10	1/32"-3/8"	J2	K2/S17	40	48	79	85,5	620
SPH-10 J33	0,8-10	1/32"-3/8"	J33	K2/S17	40	48	79	85,5	620
SPH-13 B16	0,8-13	1/32"-1/2"	B16	K3/S10	47	51	93	103	1060
SPH-13 J2	0,8-13	1/32"-1/2"	J2	K3/S10	47	51	93	103	1060
SPH-13 J33	0,8-13	1/32"-1/2"	J33	K3/S10	47	51	93	103	1060
SPH-13 J6	0,8-13	1/32"-1/2"	J6	K3/S10	47	51	93	103	1060
SPH-16 B16	3-16	1/8"-5/8"	B16	K3/S10	51,5	53	95	105,5	1210
SPH-16 B18	3-16	1/8"-5/8"	B18	K3/S10	51,5	53	95	105,5	1210
SPH-16 J6	3-16	1/8"-5/8"	J6	K3/S10	51,5	53	95	105,5	1210
SPH-20 B18	5-20	13/64"-3/4"	B18	K4/S13	64	74	121	130	2300
SPH-20 J3	5-20	13/64"-3/4"	J3	K4/S13	64	74	121	130	2300

Applications

Specifically designed for high precision drilling. The Hybrid series is well suited for use on drill presses with high accuracy, jigbore machines, horizontal or vertical milling machines, and production drilling machines where the application requires higher feed rates.

NEW





SP

Super Precision Keyless Drill Chuck

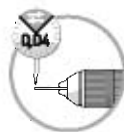

- ▶ Maximum total integrated run-out of 0,04 mm.
- ▶ Self-tightening feature automatically increases gripping force in proportion to increased torque to prevent tool shank slippage. For right-hand rotation applications only.
- ▶ Permits use on high accuracy drill presses, jig borers, milling machines and production drilling equipment.
- ▶ All components exposed to wear are completely hardened to maintain accuracy and extend chuck life.
- ▶ Also available with through hole, for EDM machines, on demand.

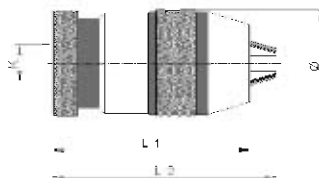

Model No.	Capacity		Mount K	Sizes mm.			Weight gr.
	mm.	Inches		Ø	L1	L2	
SP-1.5 B-6	0,2 - 1,5	0,008" - 1/16"	B - 6	19,4	35	37,3	80
SP-1.5 J-0	0,2 - 1,5	0,008" - 1/16"	J - 0	19,4	35	37,3	80
SP-03 B-6	0,3 - 3	1/64" - 1/8"	B - 6	24,5	44	47,5	200
SP-03 B-10	0,3 - 3	1/64" - 1/8"	B - 10	24,5	44	47,5	200
SP-03 J-0	0,3 - 3	1/64" - 1/8"	J - 0	24,5	44	47,5	200
SP-03 J-1	0,3 - 3	1/64" - 1/8"	J - 1	24,5	44	47,5	200
SP-03 R-5/16	0,3 - 3	1/64" - 1/8"	5/16" x 24	24,5	44	47,5	200
SP-06 B-10	0,3 - 6,5	1/64" - 1/4"	B - 10	33	62	70	360
SP-06 B-12	0,3 - 6,5	1/64" - 1/4"	B - 12	33	62	70	360
SP-06 J-1	0,3 - 6,5	1/64" - 1/4"	J - 1	33	62	70	360
SP-08 B-12	0,3 - 8	1/64" - 5/16"	B - 12	38	67	74	460
SP-08 J-1	0,3 - 8	1/64" - 5/16"	J - 1	38	67	74	460
SP-08 J-25	0,3 - 8	1/64" - 5/16"	J - 25	38	67	74	460
SP-08 R-3/8	0,3 - 8	1/64" - 5/16"	3/8" x 24	38	67	74	460
SP-10 B-12	0,5 - 10	1/32" - 3/8"	B - 12	43	81	89	720
SP-10 B-16	0,5 - 10	1/32" - 3/8"	B - 16	43	81	89	720
SP-10 J-2	0,5 - 10	1/32" - 3/8"	J - 2	43	81	89	720
SP-10 J-33	0,5 - 10	1/32" - 3/8"	J - 33	43	81	89	720
SP-10 R-3/8	0,5 - 10	1/32" - 3/8"	3/8" x 24	43	81	89	720
SP-10 R-1/2	0,5 - 10	1/32" - 3/8"	1/2" x 20	43	81	89	720
SP-13 B-16	1 - 13	1/32" - 1/2"	B - 16	49	91	103	1.000
SP-13 J-2	1 - 13	1/32" - 1/2"	J - 2	49	91	103	1.000
SP-13 J-33	1 - 13	1/32" - 1/2"	J - 33	49	91	103	1.000
SP-13 J-6	1 - 13	1/32" - 1/2"	J - 6	49	91	103	1.000
SP-13 R-1/2	1 - 13	1/32" - 1/2"	1/2" x 20	49	91	103	1.000
SP-16 B-16	3 - 16	1/8" - 5/8"	B - 16	55	95	107	1.320
SP-16 B-18	3 - 16	1/8" - 5/8"	B - 18	55	95	107	1.320
SP-16 J-33	3 - 16	1/8" - 5/8"	J - 33	55	95	107	1.320
SP-16 J-6	3 - 16	1/8" - 5/8"	J - 6	55	95	107	1.320



SPX

Super Precision Keyless Drill Chuck, with supplementary gripping torque

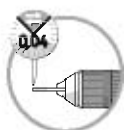

- ▶ SPX drill chucks offer the same features as SP, with the advantage of being furnished with milled wrench flats and spanner wrench to allow application of supplementary gripping torque. Light tightening increases gripping torque up to 3 times higher than hand tightening.
- ▶ For use on CNC machines in drilling, boring, counter-boring and milling operations requiring heavy feed.
- ▶ Resistance to tool loosening on high-speed machines with instant spindle stop.

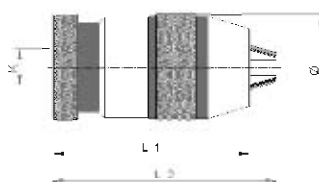

Model No.	Capacity		Mount K	Sizes mm.			Weight gr.
	mm.	Inches		Ø	L1	L2	
SPX-06 B-10	0,3 - 6,5	1/64" - 1/4"	B-10	33	62	70	580
SPX-06 B-12	0,3 - 6,5	1/64" - 1/4"	B-12	33	62	70	580
SPX-06 J-1	0,3 - 6,5	1/64" - 1/4"	J-1	33	62	70	580
SPX-08 B-12	0,3 - 8	1/64" - 5/16"	B-12	38	67	74	680
SPX-08 J-1	0,3 - 8	1/64" - 5/16"	J-1	38	67	74	680
SPX-08 J-25	0,3 - 8	1/64" - 5/16"	J-25	38	67	74	680
SPX-10 B-12	0,5 - 10	1/32" - 3/8"	B-12	43	81	89	940
SPX-10 B-16	0,5 - 10	1/32" - 3/8"	B-16	43	81	89	940
SPX-10 J-2	0,5 - 10	1/32" - 3/8"	J-2	43	81	89	940
SPX-10 J-33	0,5 - 10	1/32" - 3/8"	J-33	43	81	89	940
SPX-13 B-16	1 - 13	1/32" - 1/2"	B-16	49	91	103	1.220
SPX-13 J-2	1 - 13	1/32" - 1/2"	J-2	49	91	103	1.220
SPX-13 J-33	1 - 13	1/32" - 1/2"	J-33	49	91	103	1.220
SPX-13 J-6	1 - 13	1/32" - 1/2"	J-6	49	91	103	1.220
SPX-16 B-16	3 - 16	1/8" - 5/8"	B-16	55	95	107	1.540
SPX-16 B-18	3 - 16	1/8" - 5/8"	B-18	55	95	107	1.540
SPX-16 J-33	3 - 16	1/8" - 5/8"	J-33	55	95	107	1.540
SPX-16 J-6	3 - 16	1/8" - 5/8"	J-6	55	95	107	1.540



SPS-SOLID

Super Precision Keyless Drill Chuck with Integrated Shank (Morse taper, straight shank or R-8)



- ▶ Arbor integrated in internal socket of drill chuck; compact design.
- ▶ No possibility of taper slipping from drill chuck.
- ▶ Greater rigidity and precision.
- ▶ Maximum total integrated run-out of 0,04 mm.
- ▶ Self-tightening feature automatically increases gripping force in proportion to increased torque to prevent tool shank slippage. For right-hand rotation applications only.
- ▶ Furnished with milled wrench flats and spanner wrench to allow application of supplementary gripping torque. Light tightening increases gripping torque up to 3 times higher than hand tightening.
- ▶ Resistance to tool loosening on high-speed machines with instant spindle stop.

Compact Design
Greater Rigidity
High Precision

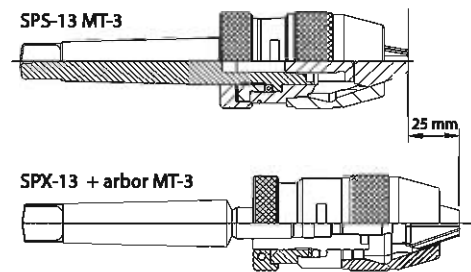

Morse Taper

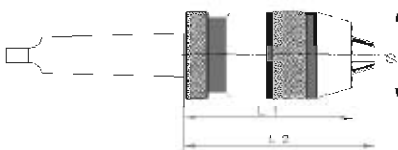

Model No.	Capacity		Mount K	Sizes mm.			Weight gr.
	mm.	Inches		Ø	L1	L2	
SPS-08 MT-2	0,3 - 8	1/64" - 5/16"	Morse Taper 2	38	65	72	800
SPS-10 MT-2	0,5 - 10	1/32" - 3/8"	Morse Taper 2	43	73	82	1.020
SPS-13 MT-2	1 - 13	1/32" - 1/2"	Morse Taper 2	48	80	92	1.200
SPS-13 MT-3	1 - 13	1/32" - 1/2"	Morse Taper 3	48	80	92	1.320
SPS-13 MT-4	1 - 13	1/32" - 1/2"	Morse Taper 4	48	80	92	1.580
SPS-16 MT-2	3 - 16	1/8" - 5/8"	Morse Taper 2	54	85	96	1.600
SPS-16 MT-3	3 - 16	1/8" - 5/8"	Morse Taper 3	54	85	96	1.720
SPS-16 MT-4	3 - 16	1/8" - 5/8"	Morse Taper 4	54	85	96	1.980

Straight Shank

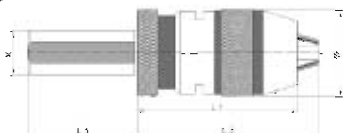

SPS-13 CIL-20	1 - 13	1/32" - 1/2"	Ø mm. 20	48	80	92	60	1.320
SPS-13 CIL-25	1 - 13	1/32" - 1/2"	Ø mm. 25	48	80	92	61	1.320
SPS-13 CIL-32	1 - 13	1/32" - 1/2"	Ø mm. 32	48	80	92	63	1.440
SPS-16 CIL-20	3 - 16	1/8" - 5/8"	Ø mm. 20	54	88	98	60	1.600
SPS-16 CIL-25	3 - 16	1/8" - 5/8"	Ø mm. 25	54	88	98	61	1.680
SPS-16 CIL-32	3 - 16	1/8" - 5/8"	Ø mm. 32	54	88	98	63	1.800

R-8

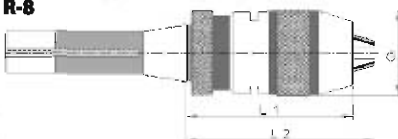

SPS-13 R-8	1 - 13	1/32" - 1/2"	R-8	48	82	90		1.580
SPS-16 R-8	3 - 16	1/8" - 5/8"	R-8	54	87	98		1.800



NPU

Super Precision Short Keyless Drill Chuck with Integrated Shank



- ▶ For use on CNC machining centres.
- ▶ Single taper connection between drill chuck and shank eliminates intermediate arbors to ensure high tool rigidity and drilling accuracy.
- ▶ Furnished with milled wrench flats and spanner wrench to allow application of supplementary gripping torque.
- ▶ Resistance to tool loosening on high-speed machines with instant spindle stop.
- ▶ Maximum total integrated run-out of 0,04 mm.

Advantages

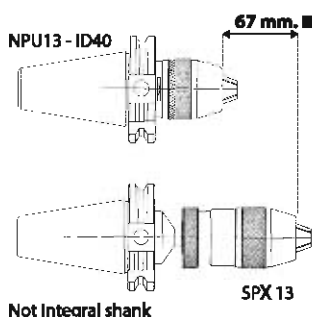

1 COMPACT CONSTRUCTION

Drill chuck model SPX-13 with DIN-69871 ISO 40 shank is 67 mm longer than drill chuck NPU-13 with the same shank. Greater rigidity and precision.

3 RETENSION SCREW

Guarantees a perfect connection between the internal arbor taper and the external arbor taper.

2 HIGHER PRECISION

The eccentricity is controlled by the single taper connection to the machine and no intermediate arbor is needed as with the standard drill chuck.

4 MAXIMUM CONNECTION RIGIDITY

The connection with a short Morse taper is the best due to its rigidity and precision.

5 ADVANTAGES OF SUPPLEMENTARY TIGHTENING BY WRENCH:

Increases gripping torque up to three times higher than hand tightening.

Capacities 0-3 mm and 0-6.5 mm available on request for all NPU models

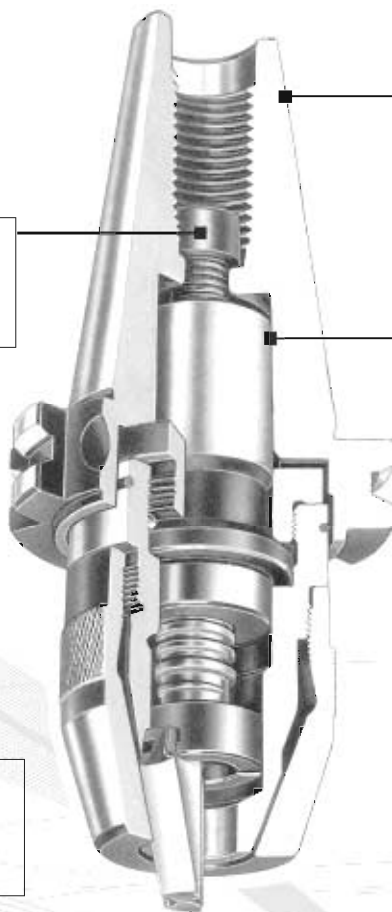

DIN-69871-A

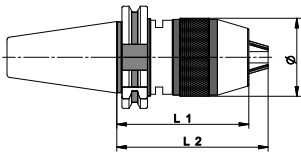

Model No.	Capacity		Mount ISO	Sizes mm.			Thread p.stud	Weight Kg
	mm.	inches		Ø	L1	L2		
NPU-08 ID 30	0,3 - 8	1/64" - 5/16"	30	38	77	83	M12	1,10
NPU-08 ID 40	0,3 - 8	1/64" - 5/16"	40	38	70	76	M16	1,50
NPU-08 ID 40/110	0,3 - 8	1/64" - 5/16"	40/110	38	110	116	M16	1,95
NPU-10 ID 30	0,5 - 10	1/32" - 3/8"	30	43	86	94	M12	1,30
NPU-10 ID 40	0,5 - 10	1/32" - 3/8"	40	43	74	82	M16	1,60
NPU-10 ID 40/110	0,5 - 10	1/32" - 3/8"	40/110	43	114	122	M16	1,95
NPU-13 ID 40	1 - 13	1/32" - 1/2"	40	48	80	91	M16	1,70
NPU-13 ID 40/125	1 - 13	1/32" - 1/2"	40/125	48	130	141	M16	2,45
NPU-13 ID 45	1 - 13	1/32" - 1/2"	45	48	78	89	M20	2,50
NPU-13 ID 50	1 - 13	1/32" - 1/2"	50	48	78	89	M24	3,65
NPU-16 ID 40	3 - 16	1/8" - 5/8"	40	55	97	108	M16	2,15
NPU-16 ID 50	3 - 16	1/8" - 5/8"	50	55	76	89	M24	3,75
NPU-16 ID 50/125	3 - 16	1/8" - 5/8"	50/125	55	130	140	M24	4,90

MAS 403-BT [JIS-6339A]

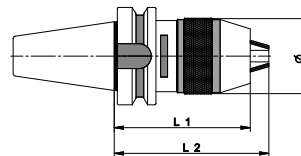

NPU-08 BT 30	0,3 - 8	1/64" - 5/16"	30	38	73	79	M12	1,10
NPU-08 BT 40	0,3 - 8	1/64" - 5/16"	40	38	78	84	M16	1,50
NPU-08 BT 40/110	0,3 - 8	1/64" - 5/16"	40/110	38	78	84	M16	1,90
NPU-10 BT 30	0,5 - 10	1/32" - 3/8"	30	43	89	97	M12	1,30
NPU-10 BT 40	0,5 - 10	1/32" - 3/8"	40	43	79	87	M16	1,70
NPU-10 BT 40/110	0,5 - 10	1/32" - 3/8"	40/110	43	109	117	M16	2,10
NPU-13 BT 40	1 - 13	1/32" - 1/2"	40	48	86	97	M16	1,90
NPU-13 BT 40/130	1 - 13	1/32" - 1/2"	40/130	48	136	147	M16	2,70
NPU-13 BT 50	1 - 13	1/32" - 1/2"	50	48	97	108	M24	4,60
NPU-16 BT 40	3 - 16	1/8" - 5/8"	40	55	105	116	M16	2,30
NPU-16 BT 50	3 - 16	1/8" - 5/8"	50	55	95	106	M24	4,70
NPU-16 BT 50/145	3 - 16	1/8" - 5/8"	50/145	55	145	156	M24	5,80

DIN-2080

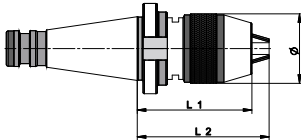

NPU-08 DIN 30	0,3 - 8	1/64" - 5/16"	30	38	70	76	M12	1,00
NPU-08 DIN 40	0,3 - 8	1/64" - 5/16"	40	38	63	69	M16	1,40
NPU-10 DIN 30	0,5 - 10	1/32" - 3/8"	30	43	77	85	M12	1,20
NPU-10 DIN 40	0,5 - 10	1/32" - 3/8"	40	43	72	80	M16	1,60
NPU-13 DIN 40	1 - 13	1/32" - 1/2"	40	48	78	89	M16	1,70
NPU-13 DIN 50	1 - 13	1/8" - 5/8"	50	48	90	101	M24	3,60
NPU-16 DIN 40	3 - 16	1/8" - 5/8"	40	55	90	101	M16	2,10
NPU-16 DIN 50	3 - 16	1/8" - 5/8"	50	55	72	83	M24	3,75

CAT-ANSI

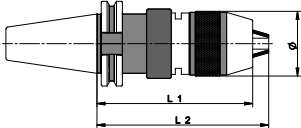

NPU-08 CA 30-A	0,3 - 8	1/64" - 5/16"	30	38	101	107	1/2"-13	0,85
NPU-08 CA 40-A	0,3 - 8	1/64" - 5/16"	40	38	82	88	5/8"-11	1,30
NPU-13 CA 40-A	1 - 13	1/32" - 1/2"	40	48	115	126	5/8"-11	1,85
NPU-13 CA 45-A	1 - 13	1/32" - 1/2"	45	48	96	107	3/4"-10	2,25
NPU-13 CA 50-A	1 - 13	1/32" - 1/2"	50	48	96	107	1"-8	2,50
NPU-16 CA 40-A	3 - 16	1/8" - 5/8"	40	55	120	131	5/8"-11	3,65
NPU-16 CA 50-A	3 - 16	1/8" - 5/8"	50	55	94	105	1"-8	3,85

DIN-69880 VDI 3425/2

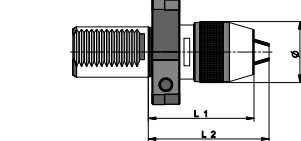

NPU-08 VDI 30	0,3 - 8	1/64" - 5/16"	30	38	72	79		1,85
NPU-13 VDI 30	1 - 13	1/32" - 1/2"	30	48	94	105		2,10
NPU-13 VDI 40	1 - 13	1/32" - 1/2"	40	48	85	92		2,40
NPU-16 VDI 40	3 - 16	1/8" - 5/8"	40	55	85	96		2,60
NPU-16 VDI 50	3 - 16	1/8" - 5/8"	50	55	87	98		3,65
NPU-16 VDI 60	3 - 16	1/8" - 5/8"	60	55	87	98		5,40

STRAIGHT SHANK

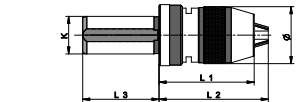

NPU-08 CIL 25	0,3 - 8	1/64" - 5/16"	25	38	66	73	56	0,85
NPU-08 CIL 30	0,3 - 8	1/64" - 5/16"	30	38	66	73	56	1,30
NPU-08 CIL 32	0,3 - 8	1/64" - 5/16"	32	38	66	73	56	1,85
NPU-13 CIL 32	1 - 13	1/32" - 1/2"	32	48	80	92	65	2,25
NPU-13 CIL 40	1 - 13	1/32" - 1/2"	40	48	80	92	65	2,50
NPU-16 CIL 40	3 - 16	1/8" - 5/8"	40	55	84	96	70	3,65
NPU-16 CIL 50	3 - 16	1/8" - 5/8"	50	55	84	96	70	3,85

DIN-69893-A [HSK]

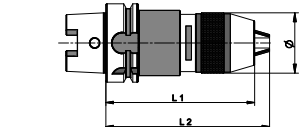

NPU-13 HSK 50	1 - 13	1/32" - 1/2"	50	48	120	131		2,10
NPU-13 HSK 63	1 - 13	1/32" - 1/2"	63	48	120	131		2,30
NPU-16 HSK 63	3 - 16	1/8" - 5/8"	63	55	131	142		2,65
NPU-16 HSK 80	3 - 16	1/8" - 5/8"	80	55	134	145		3,40
NPU-16 HSK 100	3 - 16	1/8" - 5/8"	100	55	134	145		4,40

NPU-B

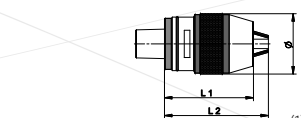

NPU-03 B	0,3 - 3	1/64" - 1/8"	B-12	24	38	41		0,12
NPU-06 B	0,3 - 6,5	1/64" - 1/4"	B-18	33	52	59		0,28
NPU-08 B	0,3 - 8	1/64" - 5/16"	B-18	38	57	64		0,38
NPU-10 B/30 ⁽¹⁾	0,5 - 10	1/32" - 3/8"	B-18	43	64	74		0,54
NPU-10 B/40 ⁽²⁾	0,5 - 10	1/32" - 3/8"	B-18	43	64	74		0,54
NPU-13 B	1 - 13	1/32" - 1/2"	MORSE-3	48	72	84		0,76
NPU-16 B/40 ⁽²⁾	3 - 16	1/8" - 5/8"	MORSE-3	54	76	88		1,06
NPU-16 B/50 ⁽³⁾	3 - 16	1/8" - 5/8"	MORSE-3	54	76	88		1,06

⁽¹⁾ for tapers 30

⁽²⁾ for tapers 40

⁽³⁾ for tapers 50



HEXA

Precision drill chuck with integrated shank and hexagonal key lock



- ▶ For use on high-speed CNC machines, optional through coolant for drilling, milling, reaming and tapping.
- ▶ Hexagonal key lock system.
- ▶ Permits clockwise and counterclockwise turning.
- ▶ High gripping torque, exceeding 100 Nm.
- ▶ Maximum total integrated run-out of 0.03 mm.
- ▶ Maximum coolant pressure: 50 bar.
- ▶ Maximum revolutions per minute without balancing: 8000.
- ▶ Optional balancing service up to 25.000 rpm G6,3.

Advantages

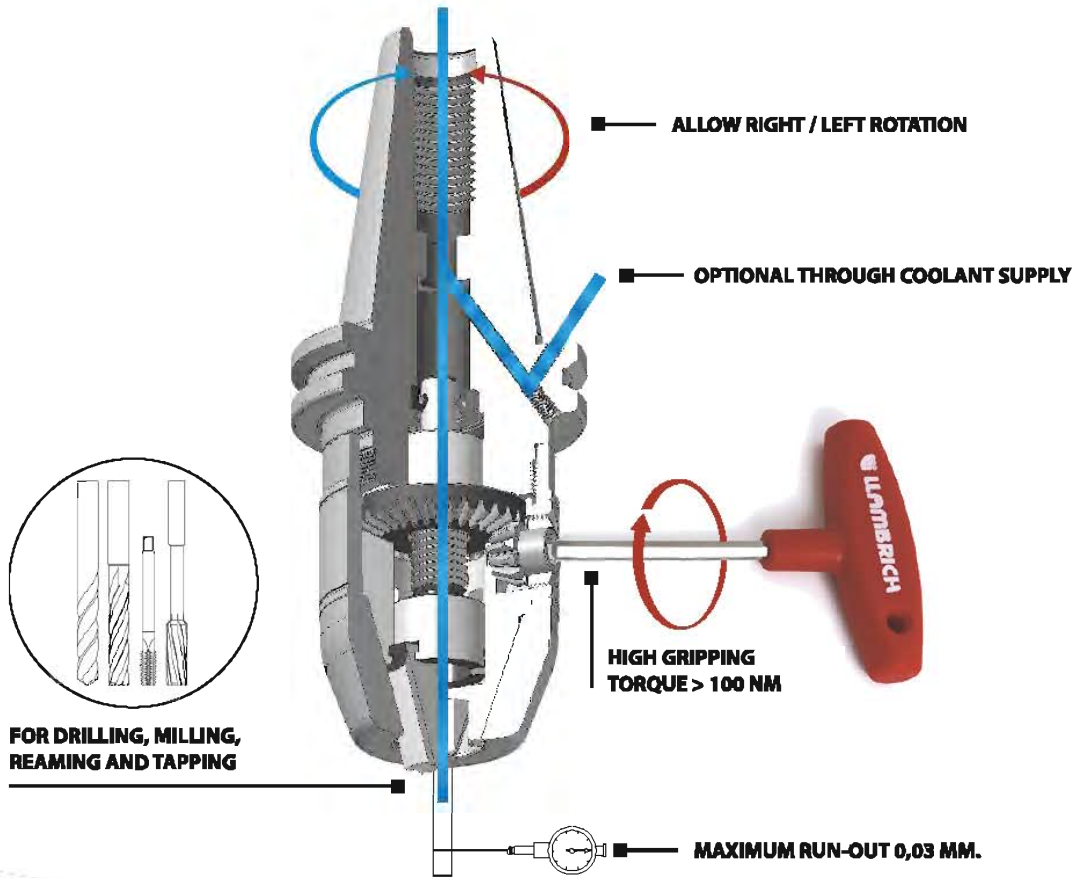

DIN-69871-A
A, B, AD

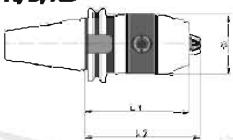

Model No.	Capacity		Mount ISO	Through coolant	Sizes mm.			Thread p.stud	Weight Kg
	mm.	inches			Ø	L1	L2		
HX-10 ID-40	0,5 - 10	1/32" - 3/8"	40	--	43	77	85,5	M16	1,3
HX-10 ID-40/R	0,5 - 10	1/32" - 3/8"	40	B+AD	43	77	85,5	M16	1,3
HX-13 ID-40	1 - 13	1/32" - 1/2"	40	--	54	91	100	M16	1,92
HX-13 ID-40/R	1 - 13	1/32" - 1/2"	40	B+AD	54	91	100	M16	1,92
HX-13 ID-50	1 - 13	1/32" - 1/2"	50	--	54	93	102	M24	3,46
HX-13 ID-50/R	1 - 13	1/32" - 1/2"	50	B+AD	54	93	102	M24	3,46
HX-16 ID-40	3 - 16	1/8" - 5/8"	40	--	57	94	101	M16	2,10
HX-16 ID-40/R	3 - 16	1/8" - 5/8"	40	B+AD	57	94	101	M16	2,10
HX-16 ID-50	3 - 16	1/8" - 5/8"	50	--	57	96	103	M24	3,56
HX-16 ID-50/R	3 - 16	1/8" - 5/8"	50	B+AD	57	96	103	M24	3,56

MAS 403-BT [JIS-6339A]
A, B, AD

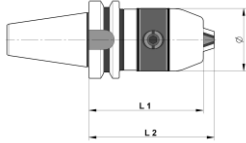

DIN-2080

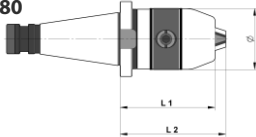

DIN-69893-A [HSK]

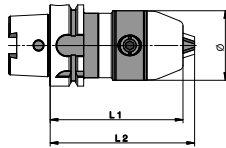

MORSE

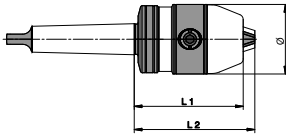

STRAIGHT SHANK

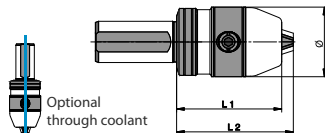

DIN-69880 VDI
A, AD

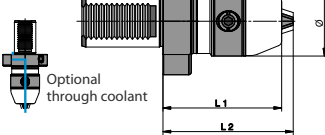

CAT-ANSI
A, AD

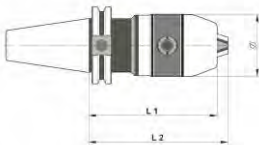

R-8

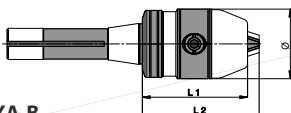

HEXA-B

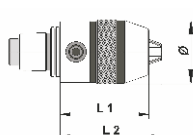

Model No.	Capacity		Mount ISO	Through coolant	Sizes mm.			Thread p.stud	Weight Kg
	mm.	inches			Ø	L1	L2		
HX-10 BT-40	0,5 - 10	1/32" - 3/8"	40	--	43	86	95	M16	1,38
HX-10 BT-40/R	0,5 - 10	1/32" - 3/8"	40	B+AD	43	86	95	M16	1,38
HX-13 BT-40	1 - 13	1/32" - 1/2"	40	--	54	96	105	M16	2,04
HX-13 BT-40/R	1 - 13	1/32" - 1/2"	40	B+AD	54	96	105	M16	2,04
HX-13 BT-50	1 - 13	1/32" - 1/2"	50	--	54	107	116	M24	4,38
HX-13 BT-50/R	1 - 13	1/32" - 1/2"	50	B+AD	54	107	116	M24	4,38
HX-16 BT-40	3 - 16	1/8" - 5/8"	40	--	57	99	106	M16	2,22
HX-16 BT-40/R	3 - 16	1/8" - 5/8"	40	B+AD	57	99	106	M16	2,22
HX-16 BT-50	3 - 16	1/8" - 5/8"	50	--	57	110	117	M24	4,48
HX-16 BT-50/R	3 - 16	1/8" - 5/8"	50	B+AD	57	110	117	M24	4,48
HX-10 DIN-40	0,5 - 10	1/32" - 3/8"	40	--	43	72	81	M16	1,22
HX-13 DIN-40	1 - 13	1/32" - 1/2"	40	--	54	82	91	M16	1,84
HX-13 DIN-50	1 - 13	1/32" - 1/2"	50	--	54	85	94	M24	3,32
HX-16 DIN-40	3 - 16	1/8" - 5/8"	40	--	57	85	92	M16	2,00
HX-16 DIN-50	3 - 16	1/8" - 5/8"	50	--	57	88	95	M24	3,42
HX-13 HSK-50	1 - 13	1/32" - 1/2"	50	--	54	112	121	--	1,38
HX-13 HSK-50 /R	1 - 13	1/32" - 1/2"	50	AD	54	112	121	--	1,38
HX-13 HSK-63	1 - 13	1/32" - 1/2"	63	--	54	98	107	--	1,78
HX-13 HSK-63 /R	1 - 13	1/32" - 1/2"	63	AD	54	103	112	--	1,78
HX-13 HSK-100	1 - 13	1/32" - 1/2"	100	--	54	110	119	--	4,38
HX-13 HSK-100 /R	1 - 13	1/32" - 1/2"	100	AD	54	98	107	--	4,38
HX-16 HSK-50	3 - 16	1/8" - 5/8"	50	--	57	115	122	--	1,88
HX-16 HSK-50 /R	3 - 16	1/8" - 5/8"	50	AD	57	115	122	--	1,88
HX-16 HSK-63	3 - 16	1/8" - 5/8"	63	--	57	101	108	--	4,48
HX-16 HSK-63 /R	3 - 16	1/8" - 5/8"	63	AD	57	106	113	--	4,48
HX-16 HSK-100	3 - 16	1/8" - 5/8"	100	--	57	113	120	--	4,48
HX-16 HSK-100 /R	3 - 16	1/8" - 5/8"	100	AD	57	101	108	--	4,48
HX-13 MT-2	1 - 13	1/32" - 1/2"	MT-2	--	54	85	94	--	1,32
HX-13 MT-3	1 - 13	1/32" - 1/2"	MT-3	--	54	85	94	--	1,48
HX-13 MT-4	1 - 13	1/32" - 1/2"	MT-4	--	54	85	94	--	1,80
HX-16 MT-2	3 - 16	1/8" - 5/8"	MT-2	--	57	88	95	--	1,42
HX-16 MT-3	3 - 16	1/8" - 5/8"	MT-3	--	57	88	95	--	1,56
HX-16 MT-4	3 - 16	1/8" - 5/8"	MT-4	--	57	88	95	--	1,88
HX-13 CIL-20	1 - 13	1/32" - 1/2"	20	--	54	85	94	--	1,30
HX-13 CIL-25	1 - 13	1/32" - 1/2"	25	--	54	82	91	--	1,40
HX-13 CIL-32	1 - 13	1/32" - 1/2"	32	--	54	82	91	--	1,56
HX-13 CIL-40	1 - 13	1/32" - 1/2"	40	--	54	82	91	--	1,86
HX-16 CIL-20	3 - 16	1/8" - 5/8"	20	--	57	88	95	--	1,40
HX-16 CIL-25	3 - 16	1/8" - 5/8"	25	--	57	85	92	--	1,48
HX-16 CIL-32	3 - 16	1/8" - 5/8"	32	--	57	85	92	--	1,64
HX-16 CIL-40	3 - 16	1/8" - 5/8"	40	--	57	85	92	--	1,94
HX-13 VDI-30	1 - 13	1/32" - 1/2"	30	--	54	90	99	--	1,74
HX-13 VDI-40	1 - 13	1/32" - 1/2"	40	--	54	92	101	--	2,30
HX-13 VDI-50	1 - 13	1/32" - 1/2"	50	--	54	96	105	--	3,32
HX-16 VDI-30	3 - 16	1/8" - 5/8"	30	--	57	93	100	--	1,82
HX-16 VDI-40	3 - 16	1/8" - 5/8"	40	--	57	95	102	--	2,38
HX-16 VDI-50	3 - 16	1/8" - 5/8"	50	--	57	99	106	--	3,40
HX-10 CA40	0,5 - 10	1/32" - 3/8"	40	--	43	100	108,5	5/8" - 11	1,50
HX-10 CA40/R	0,5 - 10	1/32" - 3/8"	40	B+AD	43	100	108,5	5/8" - 11	1,50
HX-13 CA40	1 - 13	1/32" - 1/2"	40	--	54	107	116	5/8" - 11	2,18
HX-13 CA40/R	1 - 13	1/32" - 1/2"	40	B+AD	54	107	116	5/8" - 11	2,18
HX-13 CA50	1 - 13	1/32" - 1/2"	50	--	54	88	97	1" - 8	3,86
HX-13 CA50/R	1 - 13	1/32" - 1/2"	50	B+AD	54	94	103	1" - 8	3,86
HX-16 CA40	3 - 16	1/8" - 5/8"	40	--	57	110	117	5/8" - 11	2,30
HX-16 CA40/R	3 - 16	1/8" - 5/8"	40	B+AD	57	110	117	5/8" - 11	2,30
HX-16 CA50	3 - 16	1/8" - 5/8"	50	--	57	91	98	1" - 8	3,96
HX-16 CA50/R	3 - 16	1/8" - 5/8"	50	B+AD	57	97	104	1" - 8	3,96
HX-13 R-8	1 - 13	1/32" - 1/2"	R-8	--	54	85	94	--	1,58
HX-16 R-8	3 - 16	1/8" - 5/8"	R-8	--	57	88	95	--	1,66
HX-10 B	0,5 - 10	1/32" - 3/8"	Morse 4	--	43	60	69	--	0,72
HX-10 B/R	0,5 - 10	1/32" - 3/8"	Morse 4	B+AD	43	60	69	--	0,72
HX-13 B	1 - 13	1/32" - 1/2"	Morse 4	--	54	73	85	--	1,12
HX-13 B/R	1 - 13	1/32" - 1/2"	Morse 4	B+AD	54	73	85	--	1,12
HX-16 B	3 - 16	1/8" - 5/8"	Morse 4	--	57	76	87	--	1,22
HX-16 B/R	3 - 16	1/8" - 5/8"	Morse 4	B+AD	57	76	87	--	1,22



HEXA BLACK

Standard drill chuck with integrated shank and hexagonal key lock
Great quality at a fair price



- ▶ For use on CNC machines, for drilling, milling, reaming and tapping.
- ▶ Hexagonal key lock system.
- ▶ Permits clockwise and counterclockwise rotating.
- ▶ High gripping torque, exceeding 100 Nm. = 75 ft/lbs
- ▶ Maximum total indicator run-out of 0.05 mm. = .0019"
- ▶ Maximum revolutions per minute without balancing: 8000.



ALLOWS FOR
RIGHT OR LEFT
HAND ROTATION

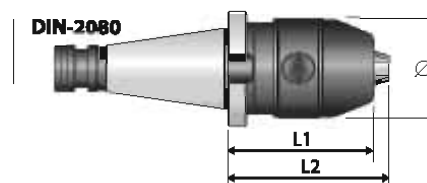
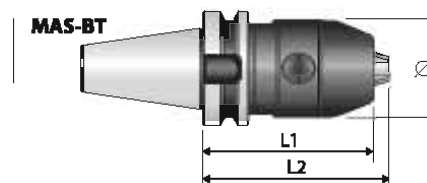
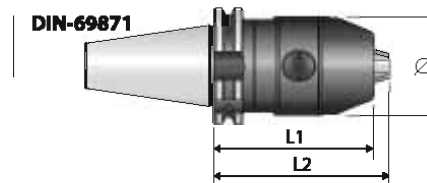

Model No.	Capacity		Mount ISO	Through coolant	Sizes mm.			Thread p.stud	Weight Kg
	mm.	Inches			Ø	L1	L2		
HB-13 ID-40	1 - 13	1/32" - 1/2"	40	--	54	91	100	M16	1,92
HB-16 ID-40	3 - 16	1/8" - 5/8"	40	--	57	94	101	M16	2,10

HB-13 BT-40	1 - 13	1/32" - 1/2"	40	--	54	96	105	M16	2,04
HB-16 BT-40	3 - 16	1/8" - 5/8"	40	--	57	99	106	M16	2,22

HB-13 DIN-40	1 - 13	1/32" - 1/2"	40	--	54	82	91	M16	1,84
HB-16 DIN-40	3 - 16	1/8" - 5/8"	40	--	57	85	92	M16	2,00

HB-13 CA40	1 - 13	1/32" - 1/2"	40	--	54	107	116	5/8" - 11	2,18
HB-16 CA40	3 - 16	1/8" - 5/8"	40	--	57	110	117	5/8" - 11	2,30

NEW





Micro DRILL

Chucks & Adapters
Ideal for micro hole drilling
Very accurate and sensitive for precise drilling

Ideal for micro hole drilling.

From 0.2 mm (0.008") to 4 mm (0.156") capacities, with the combination of a Micro Drill Chuck (3 types available) and a Sensitive Drill Feed (2 types available)

NEW

Features & Benefits

- Precision ± 0.04 mm (0.0016")
- Very accurate and sensitive for precise drilling.
- Longer tool life and less occurrence of catastrophic tool failure.
- To be used in mills, lathes, drill presses, jigbore and Swiss machines.
- Eliminates the need of secondary operations to drill small holes.
- Spindle speeds up to 50.000 RPM (SP-1.5)
- All micro drill chucks available upon request with thru hole for EDM machines.
- Micro Drill Chucks and Adapters can be supplied separately, or as part of a KIT (up to 6 combinations are available)

Simple to use

- Feed with gentle finger pressure.
- Free turning knurled ring.
- Spring return upon release.
- 20 mm (3/4") total travel.
- Standard Ø 13 mm (1/2") straight shank or #1 morse taper to go directly into the spindle of your machine or it can be held with a rotary toolholder or drill chuck.

... for a wide range of applications

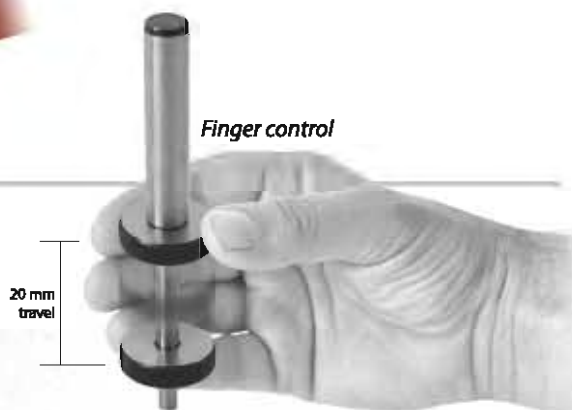

Model No.	Capacity		Mount	Key model	Sizes mm.			Weight gr
	mm.	inches			Ø	L1	L2	
SP-1.5 J0/B6	0,2-1,5	.008"-1/16"	J0/B6	-	19,3	35,3	37,5	50
SP-03 J0/B6	0,3-3	1/64"-1/8"	J0/B6	-	24,5	44,0	47,5	200
CY-04 J0/B6	0,5-4	1/64"-5/32"	J0/B6	K0	22,0	28,0	35,0	50

Model No.	Shank	Sensitive Drill Adapters	
		Mount	Weight gr
EL-MT1/J0/B6	Morse Taper 1	J0/B6	95
ECIL-13/J0/B6	Ø 13mm	J0/B6	100

KIT No.	Drill Chuck	Adapter	Weight gr
KIT #1	SP-1,5 J0/B6	ECIL-13/JT0/B6	150
KIT #2	SP-1,5 J0/B6	EL-MT1/JT0/B6	145
KIT #3	SP-03 J0/B6	ECIL-13/JT0/B6	300
KIT #4	SP-03 J0/B6	EL-MT1/JT0/B6	295
KIT #5	CY-04 J0/B6	ECIL-13/JT0/B6	150
KIT #6	CY-04 J0/B6	EL-MT1/JT0/B6	145

KITS include Free wedge for removing chuck from adapter

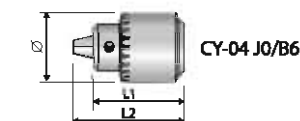
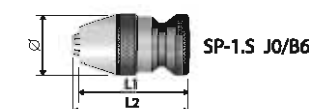

METALWORKING



AEROSPACE



ELECTRONICS



WATCH AND JEWELRY



MEDICAL INDUSTRY



HOBBY INDUSTRY



JOB SHOPS



Attractive & safe packaging for KITS



CKS

Keyless Drill Chuck for portable drilling machines or stationary machines

- ▶ Drill chucks for industrial use (medium duty), available with screw fittings for professional portable drilling machines and with taper fittings for stationary drilling machines.
- ▶ Automatic fitting for efficient, fast change of tools.
- ▶ Self-tightening mechanism automatically increases the grip in proportion to the increase in torque during the drilling and avoids the tool slipping in clockwise rotation.
- ▶ Fits tools of up to 20 mm in diameter.
- ▶ Machine fitting via DIN-238 or JACOBS tapers and UNF thread fittings.

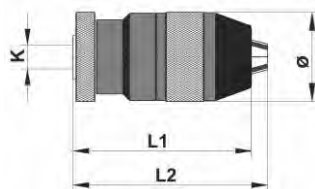

BL = blister packaging

Model No.	Capacity		Mount K	Sizes mm.			Weight gr
	mm.	inches		Ø	L1	L2	
CKS-04 B-10	0,5 - 4	1/64" - 5/32"	B - 10	26	50	55	170
CKS-04 J-0	0,5 - 4	1/64" - 5/32"	J - 0	26	50	55	170
CKS-04 J-1	0,5 - 4	1/64" - 5/32"	J - 1	26	50	55	170
CKS-06 B-10	0,5 - 6,5	1/64" - 1/4"	B - 10	34	63	70	310
CKS-06 B-12	0,5 - 6,5	1/64" - 1/4"	B - 12	34	63	70	310
CKS-06 J-1	0,5 - 6,5	1/64" - 1/4"	J - 1	34	63	70	310
CKS-06 R-3/8	0,5 - 6,5	1/64" - 1/4"	3/8" x 24h.	34	63	70	310
CKS-08 B-10	0,8 - 8	1/32" - 5/16"	B - 10	37	72	78	450
CKS-08 B-12	0,8 - 8	1/32" - 5/16"	B - 12	37	72	78	430
CKS-08 R-3/8	0,8 - 8	1/32" - 5/16"	3/8" x 24h.	37	72	78	450
CKS-08 R-1/2	0,8 - 8	1/32" - 5/16"	1/2" x 20h.	37	72	78	450
CKS-08 J-1	0,8 - 8	1/32" - 5/16"	J - 1	37	72	78	430
CKS-08 J-2S	0,8 - 8	1/32" - 5/16"	J - 2	37	72	78	430
CKS-10 B-12	0,8 - 10	1/32" - 3/8"	B - 12	40	79	86	560
CKS-10 B-16	0,8 - 10	1/32" - 3/8"	B - 16	40	79	86	560
CKS-10 R-3/8	0,8 - 10	1/32" - 3/8"	3/8" x 24h.	37	72	78	450
CKS-10 R-3/8 BL	0,8 - 10	1/32" - 3/8"	3/8" x 24h.	37	72	78	450
CKS-10 R-1/2	0,8 - 10	1/32" - 3/8"	1/2" x 20h.	37	72	78	445
CKS-10 R-1/2 BL	0,8 - 10	1/32" - 3/8"	1/2" x 20h.	37	72	78	445
CKS-10 J-2	0,8 - 10	1/32" - 3/8"	J - 2	40	79	86	560
CKS-10 J-33	0,8 - 10	1/32" - 3/8"	J - 33	40	79	86	560
CKS-13 B-12	1 - 13	1/32" - 1/2"	B - 12	47	93	103	940
CKS-13 B-16	1 - 13	1/32" - 1/2"	B - 16	47	93	103	940
CKS-13 J-2	1 - 13	1/32" - 1/2"	J - 2	47	93	103	940
CKS-13 J-33	1 - 13	1/32" - 1/2"	J - 33	47	93	103	940
CKS-13 J-6	1 - 13	1/32" - 1/2"	J - 6	47	93	103	940
CKS-13 R-3/8	2 - 13	1/16" - 1/2"	3/8" x 24h.	40	76	83	560
CKS-13 R-3/8 BL	2 - 13	1/16" - 1/2"	3/8" x 24h.	40	76	83	585
CKS-13 R-1/2	2 - 13	1/16" - 1/2"	1/2" x 20h.	40	76	83	560
CKS-13 R-1/2 BL	2 - 13	1/16" - 1/2"	1/2" x 20h.	40	76	83	585
CKS-16 B-16	3 - 16	1/8" - 5/8"	B - 16	52	95	105	1.160
CKS-16 B-18	3 - 16	1/8" - 5/8"	B - 18	52	95	105	1.160
CKS-16 J-33	3 - 16	1/8" - 5/8"	J - 33	52	95	105	1.140
CKS-16 J-6	3 - 16	1/8" - 5/8"	J - 6	52	95	105	1.135
CKS-16 R-1/2	3 - 16	1/8" - 5/8"	1/2" x 20h.	52	95	105	1.160
CKS-16 R-5/8	3 - 16	1/8" - 5/8"	5/8" x 16h.	52	95	105	1.160
CKS-20 B-18	5 - 20	3/16" - 3/4"	B - 18	64	121	131	2.200
CKS-20 B-22	5 - 20	3/16" - 3/4"	B - 22	64	121	131	2.220
CKS-20 J-3	5 - 20	3/16" - 3/4"	J - 3	64	121	131	2.200

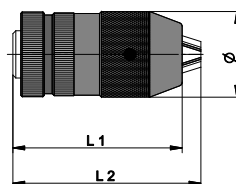

BL = blister packaging

CKX

Keyless Drill Chuck with SECURITY LOCK for percussion drilling machines

- ▶ Drill chucks with self-tightening system and a safety locking device that avoids any slipping of the drill bit.
- ▶ Optimum for hammer and stationary drills with instant spindle stoppage.
- ▶ Fits tools of up to 13 mm in diameter.
- ▶ Machine fitting via DIN-238 and UNF thread fittings.

Model No.	Capacity		Mount K	Sizes mm.			Weight gr
	mm.	inches		Ø	L1	L2	
CKX-10 B-12	0,8 - 10	1/32" - 3/8"	B - 12	36	65	74	360
CKX-10 R-3/8	0,8 - 10	1/32" - 3/8"	3/8" x 24h.	36	65	74	350
CKX-10 R-3/8 BL	0,8 - 10	1/32" - 3/8"	3/8" x 24h.	36	65	74	350
CKX-10 R-1/2	0,8 - 10	1/32" - 3/8"	1/2" x 20h.	36	65	74	350
CKX-10 R-1/2 BL	0,8 - 10	1/32" - 3/8"	1/2" x 20h.	36	65	74	350
CKX-13 B-12	1 - 13	1/32" - 1/2"	B - 12	44	86	96	650
CKX-13 B-16	1 - 13	1/32" - 1/2"	B - 16	44	86	96	650
CKX-13 R-3/8	1 - 13	1/32" - 1/2"	3/8" x 24h.	44	83	92	670
CKX-13 R-3/8 BL	1 - 13	1/32" - 1/2"	3/8" x 24h.	44	83	92	670
CKX-13 R-1/2	1 - 13	1/32" - 1/2"	1/2" x 20h.	44	83	92	670
CKX-13 R-1/2 BL	1 - 13	1/32" - 1/2"	1/2" x 20h.	44	83	92	670



CPL
Keyless Drill Chuck for portable drilling machines

- ▶ Ideal for portable electric drilling machines, on mains or battery operated.
- ▶ Does not require a chuck key for tightening or loosening, enabling production increase.
- ▶ Ergonomic design, using materials which eliminate the possibility of oxidation.
- ▶ Fits any type of drill, via UNF thread, male and female.
- ▶ Wide range of ACCESSORIES (see more info in our Price List).

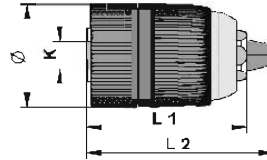

Note:
M* = means male thread
BL = blister packaging

Model No.	Capacity		Mount K	Sizes mm.			Weight gr
	mm.	inches		Ø	L1	L2	
CPL-10 R-3/8	1 - 10	1/32" - 3/8"	3/8" x 24 UNF	41	57	65	180
CPL-10 R-3/8 BL	1 - 10	1/32" - 3/8"	3/8" x 24 UNF	41	57	65	190
CPL-10 R-3/8M*	1 - 10	1/32" - 3/8"	3/8" x 24 UNF M*	41	57	65	200
CPL-10 R-3/8M* BL	1 - 10	1/32" - 3/8"	3/8" x 24 UNF M*	41	57	65	210
CPL-10 R-1/2	1 - 10	1/32" - 3/8"	1/2" x 20 UNF	41	57	65	180
CPL-10 R-1/2 BL	1 - 10	1/32" - 3/8"	1/2" x 20 UNF	41	57	65	190
CPL-13 R-3/8	2 - 13	1/16" - 1/2"	3/8" x 24 UNF	43	65	75	260
CPL-13 R-3/8 BL	2 - 13	1/16" - 1/2"	3/8" x 24 UNF	43	65	75	270
CPL-13 R-3/8M*	2 - 13	1/16" - 1/2"	3/8" x 24 UNF M*	43	65	75	280
CPL-13 R-3/8M* BL	2 - 13	1/16" - 1/2"	3/8" x 24 UNF M*	43	65	75	300
CPL-13 R-1/2	2 - 13	1/16" - 1/2"	1/2" x 20 UNF	43	65	75	260
CPL-13 R-1/2 BL	2 - 13	1/16" - 1/2"	1/2" x 20 UNF	43	65	75	270
CPL-13 SDS PLUS	2 - 13	1/16" - 1/2"	SDS PLUS	43	65	75	320



CPX
Keyless Drill Chuck with PLASTIC body, LOCKING mechanism and CARBIDE JAW inserts



Carbide Jaw-Inserts

- ▶ With a locking mechanism, no key is required for closing or opening, for hammer drilling and also screwdriver operations.
- ▶ Carbide jaw-inserts (for 13 mm. capacity) reduce bit slippage and enhance wear resistance.
- ▶ Ergonomic design, using materials that eliminate the possibility of rust.
- ▶ With through hole for clockwise and anticlockwise rotation.
- ▶ Supplied with screw M5 (R-3/8") or M6 (R-1/2") to fix chuck to drilling machine.
- ▶ Fits any type of drill (up to 1000W) via UNF thread, male and female.
- ▶ Wide range of ACCESSORIES (see more info in our Price List).

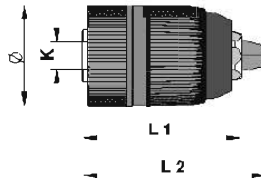

Model No.	Capacity		Mount K	Sizes mm.			Weight gr
	mm.	inches		Ø	L1	L2	
CPX-10 R-3/8	1 - 10	1/32" - 3/8"	3/8" x 24 UNF	41	57	66	220
CPX-10 R-3/8 BL	1 - 10	1/32" - 3/8"	3/8" x 24 UNF	41	57	66	230
CPX-10 R-3/8M*	1 - 10	1/32" - 3/8"	3/8" x 24 UNF M*	41	57	66	240
CPX-10 R-3/8M* BL	1 - 10	1/32" - 3/8"	3/8" x 24 UNF M*	41	57	66	250
CPX-10 R-1/2	1 - 10	1/32" - 3/8"	1/2" x 20 UNF	41	57	66	220
CPX-10 R-1/2 BL	1 - 10	1/32" - 3/8"	1/2" x 20 UNF	41	57	66	230
CPX-13 R-3/8	2 - 13	1/16" - 1/2"	3/8" x 24 UNF	42	65	75	280
CPX-13 R-3/8 BL	2 - 13	1/16" - 1/2"	3/8" x 24 UNF	42	65	75	290
CPX-13 R-3/8M*	2 - 13	1/16" - 1/2"	3/8" x 24 UNF M*	42	65	75	295
CPX-13 R-3/8M* BL	2 - 13	1/16" - 1/2"	3/8" x 24 UNF M*	42	65	75	300
CPX-13 R-1/2	2 - 13	1/16" - 1/2"	1/2" x 20 UNF	42	65	75	280
CPX-13 R-1/2 BL	2 - 13	1/16" - 1/2"	1/2" x 20 UNF	42	65	75	290
CPX-13 SDS PLUS	2 - 13	1/16" - 1/2"	SDS PLUS	42	65	75	340



CPM
Keyless Drill Chuck with METAL BODY, LOCKING mechanism and CARBIDE JAW inserts



Carbide Jaw-Inserts

- ▶ With a locking mechanism, no key is required for closing or opening, for hammer drilling and also screwdriver operations.
- ▶ Carbide jaw-inserts (for 13 mm. capacity) reduce bit slippage and enhance wear resistance.
- ▶ Ergonomic and strong design with full metal sleeves in black oxide finish that eliminates the possibility of rust.
- ▶ With through hole for clockwise and anticlockwise rotation.
- ▶ Supplied with screw M5 (R-3/8") or M6 (R1/2") to fix chuck to drilling machine.
- ▶ Fits any type of drill (up to 1000W) via UNF thread, male and female.
- ▶ Wide range of ACCESSORIES (see more info in our Price List).

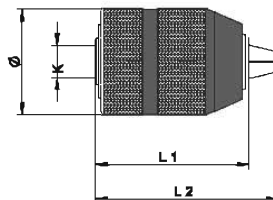

NEW COMPACT DESIGN

Model No.	Capacity		Mount K	Sizes mm.			Weight gr
	mm.	inches		Ø	L1	L2	
CPM-10 R-3/8	1 - 10	1/32" - 3/8"	3/8" x 24 UNF	41	54,5	64,5	270
CPM-10 R-3/8 BL	1 - 10	1/32" - 3/8"	3/8" x 24 UNF	41	54,5	64,5	280
CPM-10 R-3/8M*	1 - 10	1/32" - 3/8"	3/8" x 24 UNF M*	41	54,5	64,5	290
CPM-10 R-3/8M* BL	1 - 10	1/32" - 3/8"	3/8" x 24 UNF M*	41	54,5	64,5	300
CPM-10 R-1/2	1 - 10	1/32" - 3/8"	1/2" x 20 UNF	41	54,5	64,5	270
CPM-10 R-1/2 BL	1 - 10	1/32" - 3/8"	1/2" x 20 UNF	41	54,5	64,5	280
CPM-13 R-3/8	2 - 13	1/16" - 1/2"	3/8" x 24 UNF	43	62,5	74,5	320
CPM-13 R-3/8 BL	2 - 13	1/16" - 1/2"	3/8" x 24 UNF	43	62,5	74,5	330
CPM-13 R-3/8M*	2 - 13	1/16" - 1/2"	3/8" x 24 UNF M*	43	62,5	74,5	340
CPM-13 R-3/8M* BL	2 - 13	1/16" - 1/2"	3/8" x 24 UNF M*	43	62,5	74,5	350
CPM-13 R-1/2	2 - 13	1/16" - 1/2"	1/2" x 20 UNF	43	62,5	74,5	320
CPM-13 R-1/2 BL	2 - 13	1/16" - 1/2"	1/2" x 20 UNF	43	62,5	74,5	330
CPM-13 SDS PLUS	2 - 13	1/16" - 1/2"	SDS PLUS	43	62,5	74,5	380

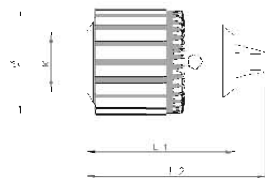
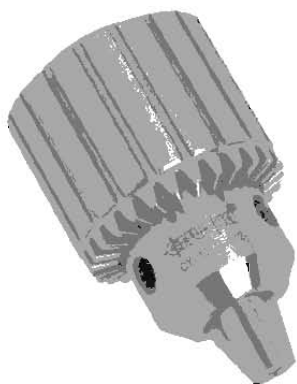

CY

INDUSTRIAL Drill Chuck with key for stationary machines and portable drilling machines

- ▶ Specially designed for stationary drilling, turning, milling and wood working machines.
 - ▶ The one-piece gear ring and sleeve eliminate the possibility of tooth breakage.
 - ▶ The jaws, gear ring and body are all totally hardened to avoid wear and lengthen the life of the drill chuck.
 - ▶ Fits tools of up to 19 mm in diameter. (3/4").
- Machine fitting via DIN-238 or JACOBS tapers and UNF screw fittings.
- ▶ Wide range of ACCESSORIES (see more info in our Price List).

Model No.	Capacity		Mount K	Sizes mm.			Weight gr
	mm.	inches		Ø	L1	L2	
CY-04 B-10	0,8 - 4	1/32" - 5/32"	B - 10	22	38	44	120
CY-04 J-0	0,8 - 4	1/32" - 5/32"	J - 0	22	29	36	100
CY-04 R-5/16	0,8 - 4	1/32" - 5/32"	5/16" x 24	22	38	44	130
CY-06 B-10	0,8 - 6,5	1/32" - 1/4"	B - 10	32	42	51	220
CY-06 B-12	0,8 - 6,5	1/32" - 1/4"	B - 12	32	44	54	210
CY-06 J-1	0,8 - 6,5	1/32" - 1/4"	J - 1	32	40	49	200
CY-06 R-3/8	0,8 - 6,5	1/32" - 1/4"	3/8" x 24	32	42	52	220
CY-06 R-3/8 SP*	0,8 - 6,5	1/32" - 1/4"	3/8" x 24	37	51	63	340
CY-10 B-12	1 - 10	1/32" - 3/8"	B - 12	37	51	60	300
CY-10 B-16	1 - 10	1/32" - 3/8"	B - 16	43	53	68	400
CY-10 J-1	1 - 10	1/32" - 3/8"	J - 1	37	51	60	310
CY-10 J-2	1 - 10	1/32" - 3/8"	J - 2	37	51	60	300
CY-10 J-2 SP*	1 - 10	1/32" - 3/8"	J - 2	43	55	68	420
CY-10 R-3/8	1 - 10	1/32" - 3/8"	3/8" x 24	37	51	60	300
CY-10 R-3/8 SP*	1 - 10	1/32" - 3/8"	3/8" x 24	43	53	68	420
CY-10 R-1/2	1 - 10	1/32" - 3/8"	1/2" x 20	37	51	60	300
CY-10 R-1/2 SP*	1 - 10	1/32" - 3/8"	1/2" x 20	43	53	68	420
CY-13 B-12	1 - 13	1/32" - 1/2"	B - 12	46	62	77	480
CY-13 B-16	1 - 13	1/32" - 1/2"	B - 16	46	62	77	460
CY-13 J-6	1 - 13	1/32" - 1/2"	J - 6	46	62	77	480
CY-13 J-33	1 - 13	1/32" - 1/2"	J - 33	46	62	77	480
CY-13 J-33 KD ⁽¹⁾	1 - 13	1/32" - 1/2"	33JT	46	71	86	500
CY-13 R-3/8	1 - 13	1/32" - 1/2"	3/8" x 24	46	62	77	500
CY-13 R-1/2	1 - 13	1/32" - 1/2"	1/2" x 20	46	62	77	480
CY-13 R-5/8	1 - 13	1/32" - 1/2"	5/8" x 16	46	62	77	490
CYX-13 J-2*	1 - 13	1/32" - 1/2"	J - 2	53	69	89	760
CYX-13 J-6*	1 - 13	1/32" - 1/2"	J - 6	53	69	89	740
CYX-13 J-33*	1 - 13	1/32" - 1/2"	J - 33	53	69	89	750
CYX-13 J-33C ⁽²⁾	1 - 13	1/32" - 1/2"	33JT	53	86	106	820
CY-16 B-16	1 - 16	1/32" - 5/8"	B - 16	57	77	95	920
CY-16 B-18	1 - 16	1/32" - 5/8"	B - 18	57	77	95	920
CY-16 J-6	1 - 16	1/32" - 5/8"	J - 6	57	77	95	970
CY-16 J-33	1 - 16	1/32" - 5/8"	J - 33	57	77	95	980
CY-16 J-3	1 - 16	1/32" - 5/8"	J - 3	57	77	95	940
CY-16 J-3 KD ⁽¹⁾	1 - 16	1/32" - 5/8"	3JT	57	85	102	980
CY-16 J-3 PD ⁽²⁾	1 - 16	1/32" - 5/8"	3JT	57	85	102	980
CY-16 R-1/2	1 - 16	1/32" - 5/8"	1/2" x 20	57	77	95	990
CY-16 R-5/8	1 - 16	1/32" - 5/8"	5/8" x 16	57	77	95	1.000
CY-19 B-22	3 - 19	13/64" - 3/4"	B - 22	65	85	110	1.440
CY-19 J-3	3 - 19	13/64" - 3/4"	J - 3	65	85	110	1.440
CY-19 J-3 KD ⁽¹⁾	3 - 19	13/64" - 3/4"	3JT	65	89	116	1.400
CY-19 J-3 PD ⁽²⁾	3 - 19	13/64" - 3/4"	3JT	65	89	116	1.360
CY-19 J-4	3 - 19	13/64" - 3/4"	J - 4	68	97	120	1.500
CY-19 R-3/4	3 - 19	13/64" - 3/4"	3/4" x 16	65	85	110	1.500
CY-19 R-5/8	3 - 19	13/64" - 3/4"	5/8" x 16	65	85	110	1.540

* Extra heavy duty model

⁽¹⁾ Equipped with positive drive slot

⁽²⁾ Equipped with pin type positive drive

⁽³⁾ Equipped with locking collar



CBB
BALL-BEARING Drill Chuck
with key for production
drilling equipment

Drill chuck with key for Industrial applications that require the toughest machining conditions.

Equipped with ball bearings to reduce friction in the tightening mechanism and provide a better grip on the drill shaft.

All the pieces are hardened and ground.

The one-piece gear ring and sleeve eliminate the possibility of tooth breakage.

Fits tools of up to 25 mm. (1"), machine fitting via Jacobs tapers.

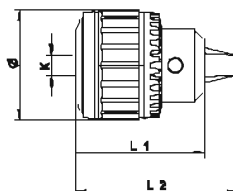

Model No.	Capacity		Mount K	Sizes mm.			Weight gr
	mm.	Inches		Ø	L1	L2	
CBB-08 J2	1 - 8	1/32" - 5/16"	J - 2S	47	55	70	500
CBB-10 J2	1 - 10	1/32" - 3/8"	J - 2S	47	55	70	500
CBB-13 J3	1 - 13	1/32" - 1/2"	J - 3	62	75	94	1.115
CBB-13 J6	1 - 13	1/32" - 1/2"	J - 6	62	75	94	1.120
CBB-16 J3	1 - 16	1/32" - 5/8"	J - 3	67	81	102	1.470
CBB-19 J4	1 - 19	1/32" - 3/4"	J - 4	75	99	125	2.145
CBB-25 J5	5 - 25	13/64" - 1"	J - 5	93	112	147	3.645



CL
LIGHT-DUTY Drill Chuck
with key for portable
drilling machines

Ideal for electric portable drilling machines, with or without batteries, cutting direction reversible or non reversible.

Fits tools of up to 16 mm.

Fits to machine via UNF screw fittings, male and female, DIN-238 and E-6.3.

Wide range of ACCESSORIES (see more info in our Price List).

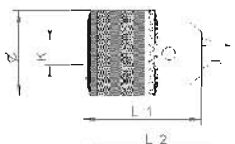

Model No.	Capacity		Mount K	Sizes mm.			Weight gr
	mm.	Inches		Ø	L1	L2	
CL-06 B-10	0,8 - 6,5	1/32" - 1/4"	B-10	30	44	55	180
CL-06 R-3/8	0,8 - 6,5	1/32" - 1/4"	3/8"x24h	30	44	55	190
CL-06 R-3/8 BL	0,8 - 6,5	1/32" - 1/4"	3/8"x24h	30	44	55	200
CL-06 ATOR	0,8 - 6,5	1/32" - 1/4"	E-6.3	30	44	55	205
CL-10 B-12	1 - 10	1/32" - 3/8"	B-12	33	50	60	240
CL-10 R-3/8	1 - 10	1/32" - 3/8"	3/8"x24h	33	50	60	240
CL-10 R-3/8 BL	1 - 10	1/32" - 3/8"	3/8"x24h	33	50	60	255
CL-10 R-3/8M ⁶	1 - 10	1/32" - 3/8"	3/8"x24h M ⁶	33	50	60	255
CL-10 R-3/8M ⁶ BL	1 - 10	1/32" - 3/8"	3/8"x24h M ⁶	33	50	60	270
CL-10 R-1/2	1 - 10	1/32" - 3/8"	1/2"x20h.	33	50	60	235
CL-10 R-1/2 BL	1 - 10	1/32" - 3/8"	1/2"x20h.	33	50	60	245
CL-10 ATOR	1 - 10	1/32" - 3/8"	E-6.3	33	50	60	255
CL-13 B-12	1,5 - 13	3/64" - 1/2"	B-12	43	59	73	360
CL-13 B-16	1,5 - 13	3/64" - 1/2"	B-16	43	59	73	355
CL-13 R-3/8	1,5 - 13	3/64" - 1/2"	3/8"x24h	43	59	73	380
CL-13 R-3/8 BL	1,5 - 13	3/64" - 1/2"	3/8"x24h	43	59	73	390
CL-13 R-3/8M ⁶	1,5 - 13	3/64" - 1/2"	3/8"x24h M ⁶	43	59	73	395
CL-13 R-3/8M ⁶ BL	1,5 - 13	3/64" - 1/2"	3/8"x24h M ⁶	43	59	73	410
CL-13 R-1/2	1,5 - 13	3/64" - 1/2"	1/2"x20h.	43	59	73	375
CL-13 R-1/2 BL	1,5 - 13	3/64" - 1/2"	1/2"x20h.	43	59	73	385
CL-13 R-5/8	1,5 - 13	3/64" - 1/2"	5/8"x16h.	43	59	73	390
CL-13 R-5/8 BL	1,5 - 13	3/64" - 1/2"	5/8"x16h.	43	59	73	395
CL-13 SDS PLUS	1,5 - 13	3/64" - 1/2"	SDS PLUS	43	59	73	420
CL-16 B-16	3 - 16	1/8" x 5/8"	B-16	54	66	85	685
CL-16 B-18	3 - 16	1/8" x 5/8"	B-18	54	66	85	685
CL-16 R-1/2	3 - 16	1/8" x 5/8"	1/2"x20h.	54	66	85	685
CL-16 R-5/8	3 - 16	1/8" x 5/8"	5/8"x16h.	54	66	85	695
CL-16 SDS PLUS	3 - 16	1/8" x 5/8"	SDS PLUS	54	66	85	730



SDS
Quick Change drill chuck
for SDS drills

- ▶ Most suitable to fix SDS drills in percussive drilling machines.
- ▶ Quick Change system enabling production increase.

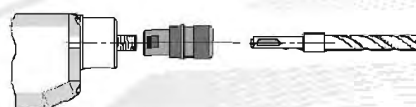

Model No.	Mount K	Weight gr
SDS-CONVERT	1/2" x 20 UNF	180



INOX

STAINLESS STEEL DRILL CHUCKS

The most complete Stainless Drill Chuck Program, available in Keyed, Keyless and also in Hybrid model types For use in the medical, dental, and food industries

NEW

Features & Benefits

- ▶ Available in Keyed or Keyless model types, or a combination of both (The Hybrid).
- ▶ Manufactured from Stainless Steel to withstand chemical corrosion.
- ▶ Identified with special laser markings to hold up to the autoclave process.
- ▶ FGE Keyless chucks have milled instead of knurled grip areas to ensure non slip hand tightening free of sharp edges. Excellent choice for use when operating with rubber gloves.
- ▶ All FGE and GE drill chuck models are bead blasted with glass balls and have passivation by a electro-polishing technique. This adds additional protection against all types of corrosion, eliminates undesirable residual contaminants, and improves the finish of the surface profile.
- ▶ For the insertion of nails, screws, pins, and other medical fasteners all chucks come with a through hole.
- ▶ Special designs, sizes, and mounts for all types of applications are available upon request.

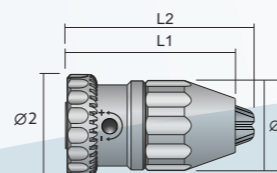
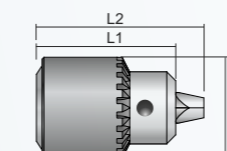
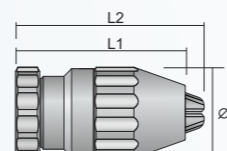
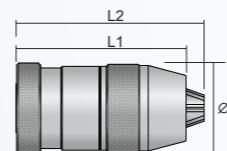

Keyless

Model No.	Capacity		Mount	Key model	Sizes mm.			Weight gr.	Equivalent Albrecht
	mm.	inches			Ø1	L1	L2		
SP-03 R-3/8 SS	0.3-3	.012-.125	3/8-24	--	24.6	43.9	47.3	110	100 N030 G02 0
SP-06 R-3/8 SS	0.3-6.5	.012-.250	3/8-24	--	33.6	62.3	69.6	300	100 N050 G02 0
SP-03 R-3/8 FGE	0.3-3	.012-.125	3/8-24	--	26.5	44.5	48.1	130	--
SP-06 R-3/8 FGE-H ⁽²⁾	0.3-6.5	.012-.250	3/8-24	--	34.2	62.7	69.5	290	--
SP-07 J1 FGE-C ⁽¹⁾	0.3-7.4	.012-.291	J-1	--	30	58	64.75	200	--
SP-07 R-3/8 FGE-C ⁽¹⁾	0.3-7.4	.012-.291	3/8-24	--	30	56	62.75	200	100 N050 G02 1

⁽¹⁾ Small Version ⁽²⁾ Large Version

Keyed

Model No.	Capacity		Mount	Key model	Sizes mm.			Weight gr.	Equivalent Jacobs
	mm.	inches			Ø1	L1	L2		
CSS-04 J0 GE	0.5-4	.020-.156	J-0	K0M	22	28	35	48	6624 / 0M
CSS-04 R-5/16 GE	0.5-4	.020-.156	5/16-24	K0M	22	30	37.4	50	6625 / 0BM 5/16
CSS-06 J1 GE-DS	0.7-7.4	.028-.291	J-1	K1M	28.4	40	50.3	110	6626 / 1M
CSS-06 R-3/8 GE-DS	0.7-7.4	.028-.291	3/8-24	K1M	28.4	40	50.3	110	6628 / 1BM 3/8
CSS-06 R-5/16 GE-DS	0.7-7.4	.028-.291	5/16-24	K1M	28.4	40	50.3	110	6627 / 1BM 5/16

THE HYBRID³

Model No.	Capacity		Mount	Key model	Sizes mm.			Weight gr.	Ø2
	mm.	inches			Ø1	L1	L2		
SPH-03 R-3/8 FGE	0.3-3	.012-.125	3/8x24	K0T	27	44.5	48	140	30
SPH-07 R-3/8 FGE-C	0.3-7.4	.012-.291	3/8-24	K1T	30	56.5	63	220	34
SPH-07 J-1 FGE-C	0.3-7.4	.012-.291	J-1	K1T	30	58.5	65	220	34

³ Llambrich Patent

- Other Mounts or Sizes available on demand for ALL Keyless, Keyed or Hybrid versions.
- Chucks with capacity up to 7.4mm or .291in are ideal to hold Zimmer accessories

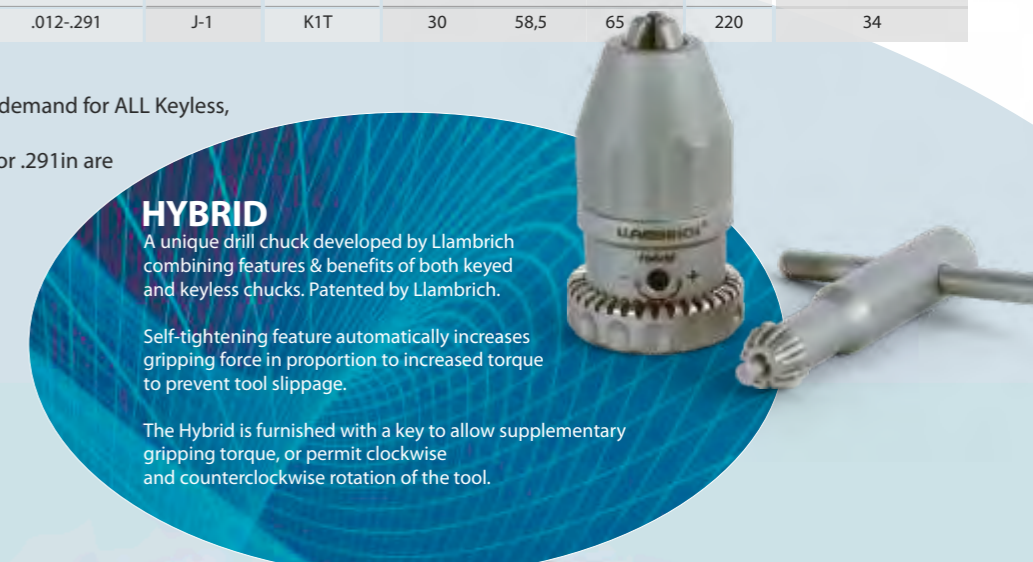

HYBRID

A unique drill chuck developed by Llambrich combining features & benefits of both keyed and keyless chucks. Patented by Llambrich.

Self-tightening feature automatically increases gripping force in proportion to increased torque to prevent tool slippage.

The Hybrid is furnished with a key to allow supplementary gripping torque, or permit clockwise and counterclockwise rotation of the tool.





Model N
 For a wide range of general turning work.

Model C
 Increases tool clearance and operator visibility for work on small parts or machining close to workpiece end.

Model H
 With centre bore 60° and metric taper point(1:20) that permits attachment of special purpose accessories.

Note 1:
 The special purpose accessories
 are not supplied by Llambrich.



Note 2:
 Llambrich revolving lathe centres may reach
 temperatures of up to 80° C due to the fine
 adjustment of the bearings with the spindle.

Revolving Lathe Centres

For accurate work holding in conventional or CNC lathes

- ▶ Llambrich revolving lathe centres are of high precision, with a maximum run-out of 0.003 mm for Morse tapers no. 2, 3, 4 and 0.004 mm for Morse taper no. 5.
- ▶ Capable of bearing up to 1,000 kg workload and speeds of up to 5,000 rpm, according to the model.
- ▶ Fully hardened and precision ground.
- ▶ Standard or extended spindle configurations.
- ▶ Maintenance free.

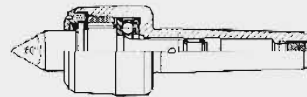

The use of needle bearings in the head and end of the turning axle, as well as the assembly of precision axial bearings, means that heavy duty work can be carried out with reduced body sizes.

Model	Maximum run-out
R-200	0,003 mm
R-300	0,003 mm
R-400	0,003 mm
R-500	0,004 mm

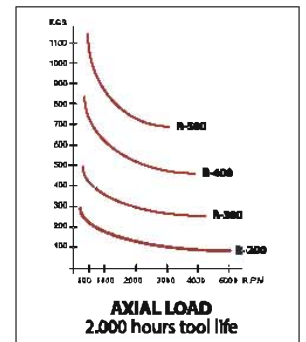
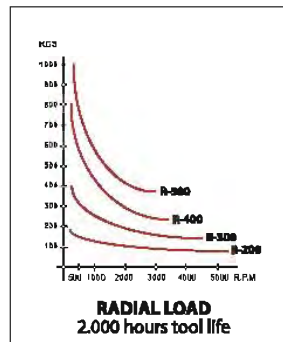

Model No.	Morse taper	Load factor kg	Sizes mm.			Weights			
			Ø1	Ø2	Ø3	L1	L2	L3	gr
R-200-N	2	180	18	42	24	35	128		430
R-300-N	3	400	22	49	29	47	163		875
R-400-N	4	800	30	63	35	52	196		1.505
R-500-N	5	1.750	33	85	48	64	250		3.955

R-300-C	3	400	22	49	10	38	47	174	875
R-400-C	4	800	30	63	11	46	52	207	1.505
R-500-C	5	1.750	33	85	18	64	64	266	3.955

R-300-H	3	550	22	49		29	47	163	905
R-400-H	4	900	24	63		37	52	196	1.540
R-500-H	5	2.100	35	85		48	64	250	4.035

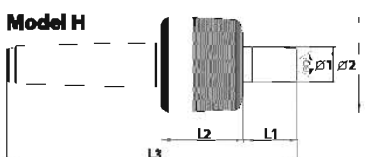
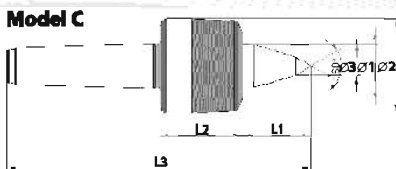
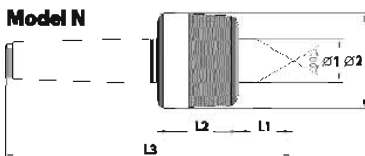

Revolving Lathe Centres

With small casing diameter



- With small diameter for optimum accessibility.
- Additional bearings to compensate the axial load.
- Morse tapers hardened and ground.
- High concentricity.
- Lubricated for life, maintenance free.

Model	Maximum run-out
R-200	0,005 mm
R-300	0,005 mm
R-400	0,005 mm
R-500	0,008 mm

Model RN

For a wide range of general turning work.

Models RC & RE

Increases tool clearance and operator visibility for work on small parts or machining close to workpiece end.

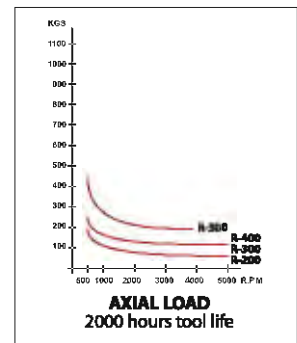
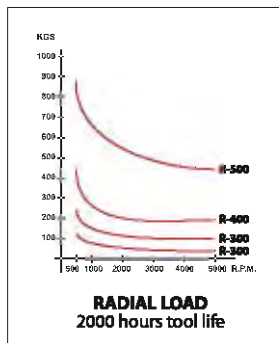

Model RN

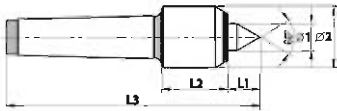

Model RC

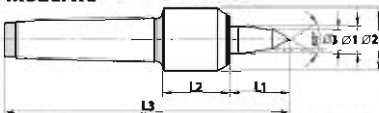

Model RE

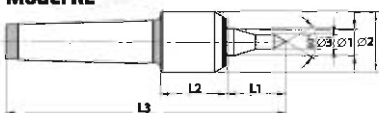

Model No.	Morse taper	Load factor kg	Sizes mm.			L1	L2	L3	Weight gr
			Ø1	Ø2	Ø3				
R-200-RN	2	200	15	32	20	39	127	300	
R-300-RN	3	400	15	34	20	40	145	500	
R-400-RN	4	800	20	43	26	42	180	1.000	
R-500-RN	5	1.200	30	58	37	60	235	2.500	

R-200-RC	2	150	15	32	8	30	39	137	300
R-300-RC	3	300	15	34	8	30	40	155	500
R-400-RC	4	700	20	43	10	36	42	190	1.000
R-500-RC	5	1.000	30	58	12	51	60	245	2.500

R-200-RE	2	130	15	32	6	30	39	137	300
R-300-RE	3	280	15	34	8	31	40	155	500
R-400-RE	4	650	20	43	10	38	42	190	1.000
R-500-RE	5	930	30	58	12	49	60	245	2.500



ARBORS for Drill Chucks

Taper Arbors: DIN-238 and JACOBS
Threaded arbors: UNF

- ▶ The arbor is an intermediary gripping element between the drill chuck (type CKS, SP and SPX) and the spindle of the machine.
- ▶ Llambrich arbors are totally hardened and precision ground, ensuring a close fit.
- ▶ Available in a wide range of DIN-238, JACOBS Morse tapers and UNF thread.
- ▶ Maximum concentricity.

Arbors DIN-238 taper

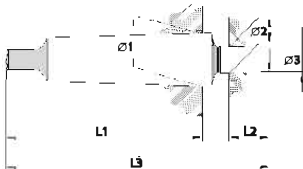

*For SP, SPX and CKS,
with shortered B18 taper

Model No.	Taper		Sizes mm.						Weight gr
	Morse	DIN-238	Ø1	Ø2	Ø3	L1	L2	L3	
E-10/1	1	10	12,065	10,095	9,4	62	14,5	85	60
E-12/1	1	12	12,065	12,065	11,1	62	18,5	89	66
E-12/2	2	12	17,78	12,065	11,1	75	18,5	106	145
E-12/3	3	12	23,825	12,065	11,1	94	18,5	126	305
E-16/1	1	16	12,065	15,733	14,5	62	24	99	90
E-16/2	2	16	17,78	15,733	14,5	75	24	111	170
E-16/3	3	16	23,825	15,733	14,5	94	24	134	335
E-16/4	4	16	31,267	15,733	14,5	117,5	24	158	650
E-16/5	5	16	44,399	15,733	14,5	149,5	24	194	1.585
E-18/1	1	18	12,065	17,78	16,2	62	32	96	105
E-18/2	2	18	17,78	17,78	16,2	75	32	118	200
E-18/3	3	18	23,825	17,78	16,2	94	32	140	355
E-18/4	4	18	31,267	17,78	16,2	117,5	32	166,5	675
E-18/5	5	18	44,399	17,78	16,2	149,5	32	202	1.605
E-18c ¹ /1	1	18c ¹	12,065	17,42	16,2	62	23	86	90
E-18c ² /2	2	18c ²	17,78	17,42	16,2	75	23	108	185
E-18c ³ /3	3	18c ³	23,825	17,42	16,2	94	23	131	325
E-18c ⁴ /4	4	18c ⁴	31,267	17,42	16,2	117,5	23	158	650
E-18c ⁵ /5	5	18c ⁵	44,399	17,42	16,2	149,5	23	189	1.570
E-22/2	2	22	17,78	21,793	19,8	75	40,5	130	265
E-22/3	3	22	23,825	21,793	19,8	94	40,5	147	410
E-22/4	4	22	31,267	21,793	19,8	117,5	40,5	176	740
E-22/5	5	22	44,399	21,793	19,8	149,5	40,5	213	1.665

Arbors Jacobs taper

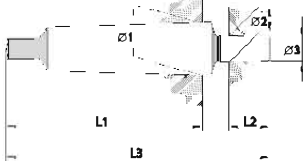

Model No.	Taper		Sizes mm.						Weight gr
	Morse	JACOBS	Ø1	Ø2	Ø3	L1	L2	L3	
E-J0/1	1	0	12,065	6,35	5,8	62	11,1	80	50
E-J1/1	1	1	12,065	9,754	8,5	62	16,7	84	56
E-J2/1	1	2	12,065	14,199	12,4	62	22,2	91	80
E-J3/1	1	3	12,065	20,599	19	62	31	101	135
E-J6/1	1	6	12,065	17,17	15,9	62	25,4	95	100
E-J33/1	1	33	12,065	15,85	14,2	62	25,4	95	95
E-J1/2	2	1	17,78	9,754	8,5	75	16,7	101	136
E-J2/2	2	2	17,78	14,199	12,4	75	22,2	106	155
E-J3/2	2	3	17,78	20,599	19	75	31	113	206
E-J6/2	2	6	17,78	17,17	15,9	75	25,4	107	170
E-J33/2	2	33	17,78	15,85	14,2	75	25,4	107	165
E-J1/3	3	1	23,825	9,754	8,5	94	16,7	120	290
E-J2/3	3	2	23,825	14,199	12,4	94	22,2	126	310
E-J3/3	3	3	23,825	20,599	19	94	31	132	360
E-J6/3	3	6	23,825	17,17	15,9	94	25,4	129	330
E-J33/3	3	33	23,825	15,85	14,2	94	25,4	127	310
E-J4/3	3	4	23,825	28,55	26,3	94	42,1	142	495
E-J5/3	3	5	23,825	35,89	33,4	94	47,6	150	640
E-J2/4	4	2	31,267	14,199	12,4	117,5	22,2	151	630
E-J3/4	4	3	31,267	20,599	19	117,5	31	161	690
E-J6/4	4	6	31,267	17,17	15,9	117,5	25,4	155	650
E-J33/4	4	33	31,267	15,85	14,2	117,5	25,4	155	640
E-J4/4	4	4	31,267	28,55	26,3	117,5	42,1	170	810
E-J5/4	4	5	31,267	35,89	33,4	117,5	47,6	175	1.000
E-J3/5	5	3	44,399	20,599	19	149,5	31	192	1.580
E-J4/5	5	4	44,399	28,55	26,3	149,5	42,1	200	1.700
E-J5/5	5	5	44,399	35,89	33,4	149,5	47,6	210	1.920
E-J6/5	5	6	44,399	17,17	15,9	149,5	25,4	185	1.540

Threaded arbors UNF

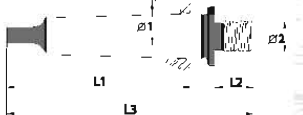

Model No.	Morse taper	Thread UNF	Sizes mm.						Weight gr
			Ø1	Ø2	Ø3	L1	L2	L3	
E-MT2-3/8	2	3/8" x 24	17,78	9,28		75	13,02	97	140
E-MT2-1/2	2	1/2" x 20	17,78	12,52		75	15,85	100	160
E-MT2-5/8	2	5/8" x 16	17,78	15,86		75	17,75	103	180



Drill SLEEVES

DIN-2185

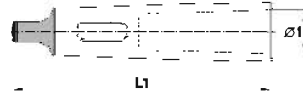

Model No.	Morse taper		Sizes mm.		Weight gr
	outside	inside	Ø1	L1	
CR-2 x 1	2	1	12,065	92	100
CR-3 x 1	3	1	12,065	99	220
CR-3 x 2	3	2	17,78	112	190
CR-4 x 1	4	1	12,065	124	535
CR-4 x 2	4	2	17,78	124	460
CR-4 x 3	4	3	23,825	140	405
CR-5 x 1	5	1	12,065	156	1.700
CR-5 x 2	5	2	17,78	156	1.520
CR-5 x 3	5	3	23,825	156	1.360
CR-5 x 4	5	4	31,267	171	950
CR-6 x 2	6	2	17,78	219	4.300
CR-6 x 3	6	3	23,825	219	4.100
CR-6 x 4	6	4	31,267	219	3.600
CR-6 x 5	6	5	44,39	219	2.550

- ▶ Completely hardened and ground, both internally and externally.
- ▶ Wide range.



Extension SLEEVES

DIN-2187

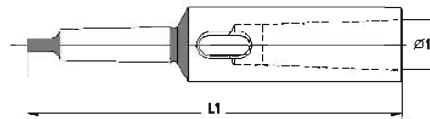

Model No.	Morse taper		Sizes mm.		Weight gr
	outside	inside	Ø1	L1	
CP 1x1	1	1	12,065	145	190
CP 1x2	1	2	17,78	160	400
CP 2x1	2	1	12,065	160	290
CP 2x2	2	2	17,78	175	500
CP 2x3	2	3	23,825	196	600
CP 3x1	3	1	12,065	175	410
CP 3x2	3	2	17,78	194	620
CP 3x3	3	3	23,825	215	890
CP 3x4	3	4	31,267	240	1.550
CP 4x1	4	1	12,065	200	810
CP 4x2	4	2	17,78	215	1.000
CP 4x3	4	3	23,825	240	1.270
CP 4x4	4	4	31,267	265	1.930
CP 4x5	4	5	44,39	300	3.180
CP 5x1	5	1	12,065	232	1.790
CP 5x2	5	2	17,78	247	2.000
CP 5x3	5	3	23,825	268	2.270
CP 5x4	5	4	31,267	300	2.930
CP 5x5	5	5	44,39	335	4.180
CP 6x4	6	4	31,267	355	5.180
CP 6x5	6	5	44,39	390	6.430

- ▶ Completely hardened and ground, both internally and externally.
- ▶ Wide range.



EJECTORS

DIN-317



Model No.	For Morse taper	Weight gr
CE 1 - 2	1, 2	40
CE 2 - 3	2, 3	80
CE 3 - 4	3, 4	160
CE 4 - 5	4, 5	340
CE 5 - 6	5, 6	620

- ▶ Tempered steel.
- ▶ To eject Morse tapers arbors from sleeves or machine spindle.

LLAMBRICH

Super Precision Drill Chucks

LLAMBRICH Precisión, S.L.

Av. Mare de Deu de Bellvitge, 271-273
E-08907 L'Hospitalet de Llobregat
Barcelona - Spain

Tel. int. +34 93 264 96 23
Fax int. +34 93 263 40 10

www.llambrich.com
e-mail: export@llambrich.com

Member of



Machine Tool, Accessories, Component
Parts and Tools Manufacturers'
Association of Spain