

Our hydraulic chucks gives you:

- Possibility to work with closer tolerances.
- Improved surface finish.
- Up to 50% longer tool lifetime compared to other conventional tool holder systems
- High clamping force. Example: 320 Nm on a standard hydro chuck Ø20 mm.
- Runout accuracy better than 0,003 mm.
- Faster and simpler tool changes. No extra equipment needed.
- Balanced for 10 000 RPM. Can be supplied fine balanced.

Appart from our standard assortment you can decide what your chuck should look like.

DRILLING

MILLING

REAMING

THREAD MILLING



Hydraulic chucks **HC**

The widest assortment on the market. For all applications.



Maximum stability with SPV Spintec's unique hexagonal milling membrane (+)

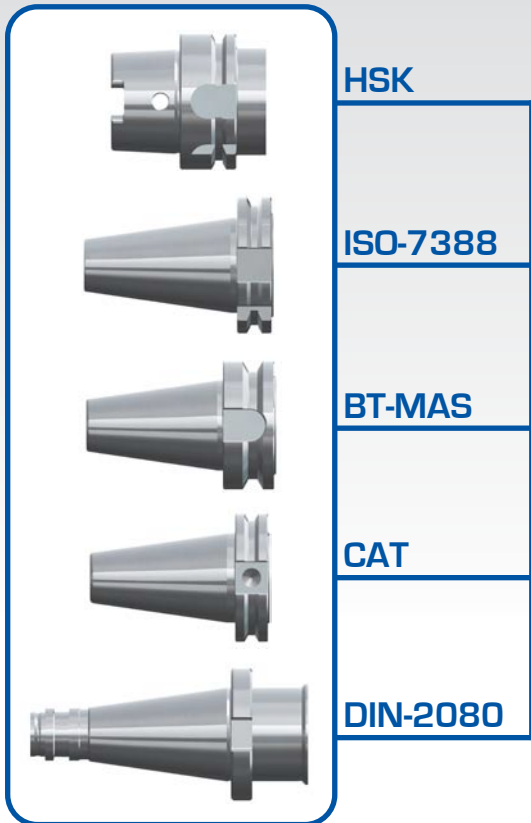
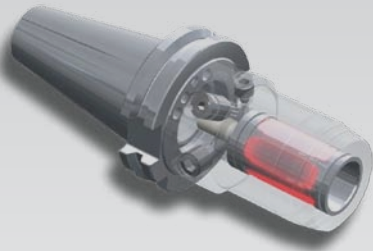

Extra short chuck HCK+ for better milling performance. Milling membrane (+) as standard. (Example: 600Nm with Ø20) HSK-A63, ISO-40 & BT-40 available.

HCF
HCF+

Short standard chuck
Also available with milling membrane (+)

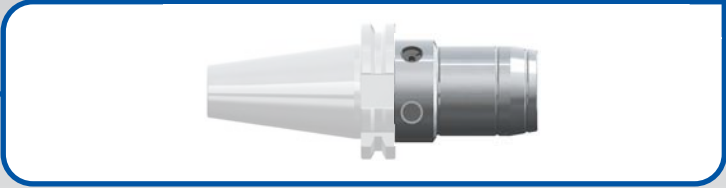

HCFL
HCFL+

Extra long standard chuck
Also available with milling membrane (+)



HCPK+

Tapered long chuck with milling membrane (+) as standard

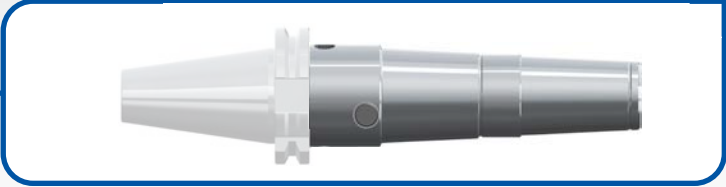

HCP+

Pen-chuck in two different lengths with milling membrane (+) as standard

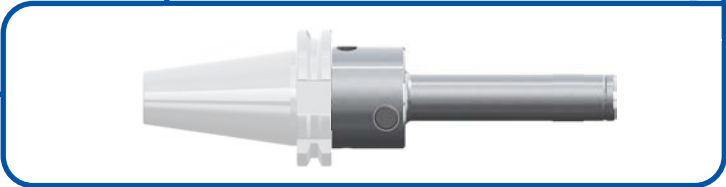

HCPS

Extra slim pen-chuck in two different lengths with standard membrane

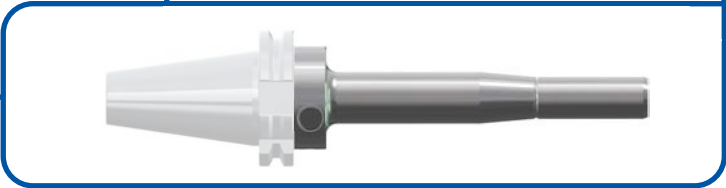

All chucks can be delivered with any machine fitting and as extended models up to 515 mm gauge length according to your needs.

Time of delivery: 2 weeks

